

# Monitor AMI-II Trides

Data sheet no. DenA26510X10

Complete monitoring system for the automatic, continuous measurement of disinfectants in water.

## Application examples

- For use in potable and pool water.

## Measuring range

- Free chlorine: 0.00 to 5.00 ppm  
Ozone: 0.000 to 1.000 ppm  
Chlorine dioxide, iodine or bromine: 0.00 to 3.00 ppm.
- Real-time pH compensation of chlorine measurement with optional pH sensor.
- Automatic temperature compensation.

## Instrument features

- Reagent-free measurement.
- pH and/or redox measurement available as an option.
- Integrated flow monitoring and continuous mechanical sensor cleaning with combined flow meter/wiper.

## Control functions

- Signal outputs and potential-free contacts flexibly configurable as control outputs
- Optional AMI-II Relay Box for direct power supply and control of dosing devices, e.g. one or two solenoid valves or one motor valve.
- Relay input to freeze the measured value or to interrupt control in automated installations.

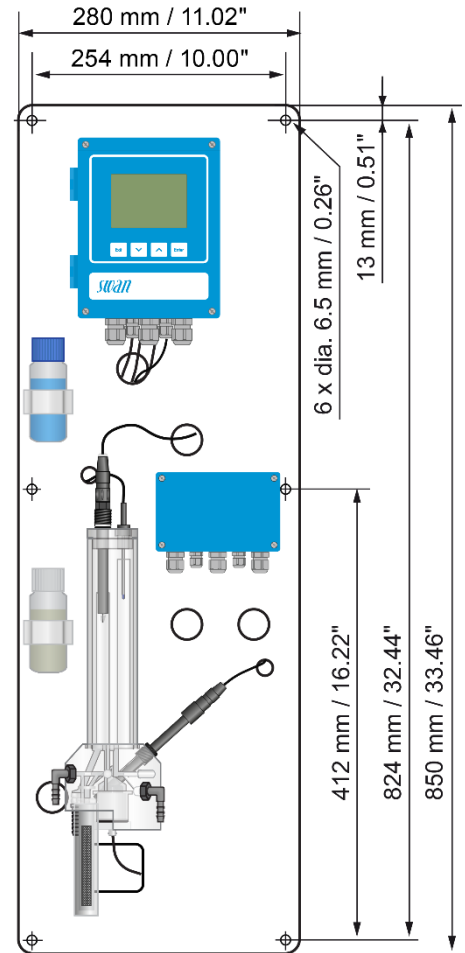

Monitor AMI-II Trides with AMI-II Relay Box and pH option

Order numbers:	Monitor AMI-II Trides	A-26.510_10
Power supply	100 – 240 VAC, 50/60 Hz..... 10 – 36 VDC.....	1 2
Option 1	RS485 interface with Modbus RTU or Profibus protocol ..... HART interface ..... Two additional 0/4 – 20 mA signal outputs .....	A-81.470.0X0 A-81.470.030 A-81.470.040
Option 2	pH sensor .....	A-87.127.030
Option 3	Redox sensor .....	A-87.427.030
Option 4	AMI-II Relay Box .....	A-89.812.200



## Disinfectant Measurement

### Disinfectant sensor type

Membrane-free three-electrode amperometric sensor.

### Measuring range

### Accuracy

Measuring range	Accuracy
Ozone	
0.000 to 1.000 ppm	±0.005 ppm
HOCl, free chlorine	
0.00 to 1.00 ppm	±0.01 ppm
1.00 to 3.00 ppm	±0.06 ppm
3.00 to 5.00 ppm	±0.2 ppm
Chlorine dioxide, iodine, bromine	
0.00 to 1.00 ppm	±0.01 ppm
1.00 to 3.00 ppm	±0.06 ppm

Stability (HOCl): ±1% from end of interval during 1 month at normal conditions.

Response time: 90% of change of excessive Cl<sub>2</sub> in 60 seconds after sample enters the flow cell.

### Auxiliary sensors

- Temperature measurement with NT5k type sensor.
 

Measuring range:	-30 to +130 °C
Accuracy (0-50 °C)	±0.2 °C
Resolution:	0.1 °C
- Integrated sample flow monitoring.
- pH (option)
 

Measuring range:	2 to 12 pH
Resolution:	0.01 pH
- Redox (option)
 

Measuring range:	-400 to +1200 mV
Resolution:	1 mV

### Restrictions of use

Presence of following substances may perturb the measurement: cyanuric acid, 5,5-Dimethylhydantoin, phosphates, copper, sand.

## Transmitter Specifications and Functionality

Electronics case: Cast aluminum  
 Protection degree: IP66 / NEMA 4X  
 Display: backlit LCD, 74 × 53 mm  
 Electrical connectors: screw clamps  
 Ambient temperature: -10 to +50 °C  
 Humidity: 10 - 90% rel., non-condensing

### Power supply

AC version: 100 – 240 VAC (±10 %),  
 50/60 Hz (±5 %)  
 DC version: 10 – 36 VDC  
 Power consumption: max. 35 VA

### Operation

User menus in English, German, French, Spanish and Italian.  
 Separate, menu-specific password protection.

### Safety features

No data loss after power failure, all data is saved in non-volatile memory.

## Electrical Connection Scheme

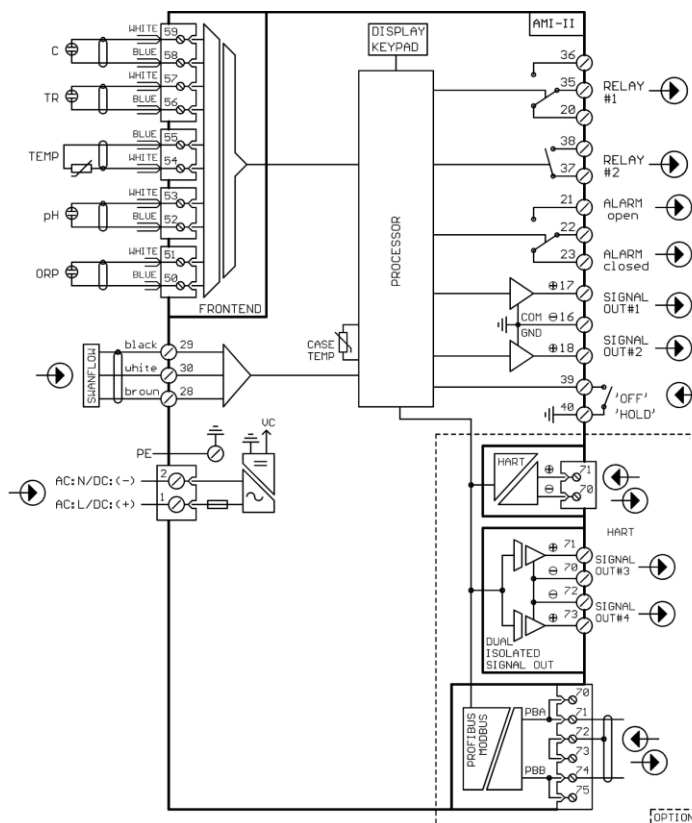

Overvoltage protection of inputs and outputs. Galvanic separation of measuring inputs from signal outputs.

### Alarm relay

One potential-free contact for summary alarm indication for programmable alarm values and instrument faults.  
 Maximum load: 1 A / 250 VAC

### Input

One input for potential-free contact. Programmable hold or remote off function.

### Relay outputs

Two potential-free contacts programmable as limit switches for measured values, controllers or timers with automatic hold function.  
 Rated load: 1 A / 250 VAC

### Signal outputs

Two or four (with optional communication interface) programmable signal outputs for measured values (freely scalable, linear or bilinear) or as controller outputs.  
 Current loop: 0/4 – 20 mA  
 Maximum burden: 510 Ω  
 Type: current source

### SD card interface

Possibility to record measured values and diagnostic data to an SD card. SD card included.

### Communication interface options

- Two additional signal outputs, galvanically separated
- RS485 interface with Modbus RTU or Profibus DP protocol, galvanically separated
- HART interface

## Monitor Data

### Sample conditions

Flow rate: approx. 40 L/h  
 Temperature: 5 to 45 °C  
 Inlet pressure: max. 2 bar  
 Outlet pressure: pressure free  
 Min. sample conductivity: 5 µS/cm

### Sample connections

Sample inlet: hose nozzle for flexible tube, 6 mm inner Ø  
 Sample outlet: elbow hose nozzle for flexible tube, 15 mm inner Ø

### Panel

Dimensions: 280 × 850 × 200 mm  
 Material: PVC  
 Total weight: 6 kg

