

AMI-II LineTOC

Operator's Manual

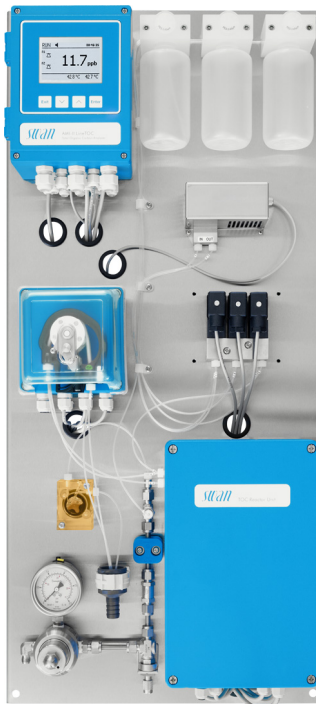

 MADE IN
SWITZERLAND



Customer Support

Swan and its representatives maintain a fully trained staff of technical specialists around the world. For any technical question, contact your nearest Swan representative, or the manufacturer:

Swan Analytische Instrumente AG
Studbachstrasse 13
8340 Hinwil
Switzerland

Internet: www.swan.ch
E-mail: support@swan.ch

Document Status

Title:	AMI-II LineTOC Operator's Manual	
ID:	TPM-MAN-000318	
Revision	Issue	
00	Sept. 2024	First edition

© 2024, Swan Analytische Instrumente AG, Switzerland, all rights reserved.

This manual applies to firmware V1.01 and higher.
The information contained in this document is subject to change without notice.

Table of Contents

1. Safety Instructions	3
1.1. Warning Notices	4
1.2. General Safety Regulations	6
2. Product Description	7
2.1. Description of the System	10
2.2. Verification	12
2.3. Calibration	12
2.4. System Suitability Test for Pharma	13
2.5. Fluidics Overview	14
2.6. Instrument Specification	16
2.7. Instrument Overview	19
3. Installation	21
3.1. Installation Checklist	21
3.2. Mounting the Instrument	22
3.3. Connect Sample and Waste	22
3.4. Electrical Connections	23
3.4.1 Power Supply	25
3.5. Relay Contacts	26
3.5.1 Input	26
3.5.2 Alarm Relay	26
3.5.3 Relay 1 and 2	26
3.6. Signal Outputs	26
3.6.1 Signal Output 1 and 2 (Current Outputs)	26
3.7. Interface Options	27
3.7.1 Signal Outputs 3 and 4	28
3.7.2 RS485 (Profibus or Modbus Protocol)	28
3.7.3 HART	29
4. Instrument Setup	30
4.1. Standard and Stock Solutions	30
4.2. Peristaltic Pump	30
4.3. Establish Sample Flow	31
4.4. Programming	32
4.5. Commissioning	32



5. Operation	33
5.1. Keys	33
5.2. Display	34
5.3. Software Structure	36
5.4. Changing Parameters and Values	37
5.5. Data Logger	38
5.6. Grab Sample	41
6. Maintenance	42
6.1. Maintenance Schedule	43
6.2. Stop of Operation for Maintenance	44
6.3. Verification	44
6.4. Calibration	46
6.5. System Suitability Test (SST)	47
6.6. Replace the Peristaltic Pump Tubes	48
6.7. Tube Numbering	50
6.8. Replace the UV Reactor	53
6.9. Replace Air Filters	56
6.10. Longer Stop of Operation	57
7. Troubleshooting	58
7.1. Error List	58
7.2. Replacing Fuses	61
8. Program Overview	62
8.1. Messages (Main Menu 1)	62
8.2. Diagnostics (Main Menu 2)	63
8.3. Maintenance (Main Menu 3)	65
8.4. Operation (Main Menu 4)	65
8.5. Installation (Main Menu 5)	66
9. Program List and Explanations	68
10. Default Values	84

Operator's Manual

This document describes the main steps for instrument setup, operation and maintenance.

1. Safety Instructions

General	<p>The instructions included in this section explain the potential risks associated with instrument operation and provide important safety practices designed to minimize these risks.</p> <p>If you carefully follow the information contained in this section, you can protect yourself from hazards and create a safer work environment.</p> <p>More safety instructions are given throughout this manual, at the respective locations where observation is most important. Strictly follow all safety instructions in this publication.</p>
Target audience	<p>Operator: Qualified person who uses the equipment for its intended purpose.</p> <p>Instrument operation requires thorough knowledge of applications, instrument functions and software program as well as all applicable safety rules and regulations.</p>
OM location	<p>Keep the Operator's Manual in proximity of the instrument.</p>
Qualification, training	<p>To be qualified for instrument installation and operation, you must</p> <ul style="list-style-type: none">♦ read and understand the instructions in this manual as well as the Material Safety Data Sheets,♦ know the relevant safety rules and regulations.

1.1. Warning Notices

The symbols used for safety-related notices have the following meaning:



DANGER

Your life or physical wellbeing are in serious danger if such warnings are ignored.

- ◆ Follow the prevention instructions carefully.



WARNING

Severe injuries or damage to the equipment can occur if such warnings are ignored.

- ◆ Follow the prevention instructions carefully.



CAUTION

Damage to the equipment, minor injury, malfunctions or incorrect process values can be the consequence if such warnings are ignored.

- ◆ Follow the prevention instructions carefully.

Mandatory signs

The mandatory signs in this manual have the following meaning:



Safety goggles



Safety gloves

Warning signs The warning signs in this manual have the following meaning:



Electrical shock hazard



Corrosive



Harmful to health



Flammable



General warning



Attention

1.2. General Safety Regulations

Legal requirements

The user is responsible for proper system operation. All precautions must be followed to ensure safe operation of the instrument.

Spare parts and disposables

Use only official Swan spare parts and disposables. If other parts are used during the normal warranty period, the manufacturer's warranty is voided.

Modifications

Modifications and instrument upgrades shall only be carried out by an authorized service technician. Swan will not accept responsibility for any claim resulting from unauthorized modification or alteration.



WARNING

Electrical shock hazard

If proper operation is no longer possible, the instrument must be disconnected from all power lines, and measures must be taken to prevent inadvertent operation.

- ◆ To prevent from electrical shock, always make sure that the ground wire is connected.
- ◆ Service shall be performed by authorized personnel only.
- ◆ Whenever electronic service is required, disconnect instrument power and power of devices connected to
 - relay 1,
 - relay 2,
 - alarm relay.



WARNING

For safe instrument installation and operation you must read and understand the instructions in this manual.

2. Product Description

Application	<p>The content of organic impurities is one of the most important quality parameters of water for pharmaceutical purposes and of ultrapure water (UPW) in semiconductor industry, but also in other industries in which ultrapure water is produced and distributed. The application range of AMI-II LineTOC covers TOC determination in ultrapure water in all industries.</p> <p>AMI-II LineTOC is a state-of-the-art reagent-free TOC analyzer based on UV-oxidation and differential conductivity measurement by two separate sensors. The use of two conductivity sensors enables continuous measurement with short response time. The analyzer is characterized by its intelligent design that ensures superior oxidation efficiency under all conditions. The evaluation of the conductivity measurements in the instrument firmware is based on the precisely known chemical and physical properties of solutions of carbon dioxide in water, which enables accurate TOC measurement without the need for calibration of the analyzer by the user.</p>
Available models	<p>The instrument is available in two models:</p> <ul style="list-style-type: none">◆ Version mounted on vertical panel.◆ Version mounted on horizontal panel with protective cover for fluidic components as an option.
Signal outputs	<p>Two signal outputs programmable for measured values (freely scalable, linear, bilinear, log) or as continuous control output (control parameters programmable).</p> <p>Current loop: 0/4–20 mA Maximal burden: 510 Ω</p> <p>Two additional signal outputs with the same specifications available as an option.</p>
Relays	<p>Two potential-free contacts programmable as limit switches for measured values, controllers or timers with automatic hold function. Maximum load: 100 mA/50 V resistive</p>
Alarm relay	<p>Two potential-free contacts (one normally open and one normally closed contact). Summary alarm indication for programmable alarm values and instrument faults.</p> <ul style="list-style-type: none">◆ Normally open contact: Closed during normal operation, open on error and loss of power.◆ Normally closed contact: Open during normal operation, closed on error and loss of power. <p>Maximum load: 100 mA/50 V resistive</p>



Input One input for potential-free contact to freeze the measured value or to interrupt control in automated installations. Programmable as HOLD or OFF function.

Communication interface (optional)

- ◆ Two additional signal outputs
- ◆ RS485 with fieldbus protocol Modbus RTU or Profibus DP
- ◆ HART

Safety features No data loss after power failure. All data is saved in non-volatile memory. Overvoltage protection of inputs and outputs. Galvanic separation of measuring inputs from signal outputs.

Operating modes The analyzer provides the following operating modes:

- ◆ On-line mode
- ◆ Grab sample mode

In on-line mode, the sample is sucked through the system from the sample inlet and measured.

In grab sample mode, the sample is sucked through the system from a bottle and measured. The bottle is fixed on position 2.

Conductivity model See [Conductivity model CO₂, p. 10](#) and [Conductivity model coefficient, p. 11](#) for a detailed description of the conductivity models.

Note: In “Pharma” measuring mode, the conductivity model is automatically set to CO₂ and cannot be selected.

Measuring modes The menu structure is divided in the two different main parts “Pharma” and “UPW” called measuring modes.

Tests Depending on the selected measuring mode and conductivity model, the following tests are available:

Measuring mode	Conductivity model	Tests
Pharma	CO ₂	<ul style="list-style-type: none"> ◆ Verification ◆ SST
UPW	CO ₂	◆ None
	Coefficient	◆ Calibration

Definitions

TC	Total carbon The sum of inorganic and organic bound carbon
TIC	Total inorganic carbon The sum of inorganic carbon in dissolved and non-dissolved compounds
TOC	Total organic carbon The amount of carbon in organic compounds
WFI	Water for injection
USP	United States Pharmacopoeia
EP	European Pharmacopoeia



2.1. Description of the System

Measuring principle

The basic principle of the measurement method used is the oxidation of organic carbon to CO₂ and subsequent detection.

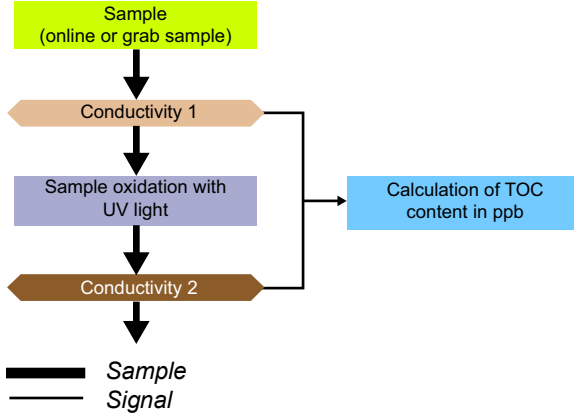

Requirements of international pharmacopoeia

International standards related to the determination of the sum parameter TOC are:

- ♦ ISO 8245 TOC in water
- ♦ USP (643) TOC in pharmaceutical water (AP, WFI)
- ♦ Ph. Eur. 2.2.44 TOC in pharmaceutical water (AP, WFI)

If the TOC content is less than a defined amount, it is assumed that the contamination is not significant from a pharmaceutical point of view.

Both standardizations have established special guidelines for the qualification of the applied method through the system suitability test (SST). System suitability refers to the ability of the instrument to efficiently oxidize a substance that is not easily oxidized.

The AMI-II LineTOC is able to perform the system suitability test automatically, the operator only needs to activate the program function and provide both standard solutions at the corresponding ports.

Analysis and calculation is then performed automatically by the instrument and shown on the display after termination of the measurements.

Conductivity model CO₂

The pharmaceutical and semiconductor industries require large amounts of deionized water with a TOC content in a low ppb range. This water contains no salt, but only organic compounds and dissolved carbon dioxide from the atmosphere.

If the organic carbon compounds

- ♦ are dissolved,
- ♦ are non-ionic (no organic acids, etc.),
- ♦ consist only of the elements C, H and O (carbon, hydrogen and oxygen),

it is possible to determine the TIC and TC by complete UV oxidation and direct conductivity measurement. If temperature and pressure are known, the conductivity of these samples is determined only by the total carbon dioxide content.

Carbon dioxide reacts with water to carbonic acid, which dissociates partially to hydrocarbonate ions and carbonate ions. The total carbon dioxide content is the sum of all these species. The composition of the sample in the chemical equilibrium is exactly determined according to the law of mass action.

Through the definite relation of conductivity and total carbon dioxide content, the TIC and TOC can be calculated from the measured conductivity of the sample.

Prior to oxidation, the conductivity corresponds to the TIC. After oxidation, the conductivity corresponds to the TC. The TOC is calculated from the difference between TC and TIC.

The determination of TIC and TOC under the above described conditions is an absolute method, i.e. for a particular TIC or TOC concentration, the conductivity is given exactly. An alignment of the conductivity with TOC calibration solutions is therefore not necessary.

If the instrument does not measure the defined TOC concentration of a standard solution within the limits of measurement accuracy, it is caused by one or more of the following reasons:

- ♦ the above described conditions are not fulfilled,
- ♦ the deviation of the measurement is caused by a defect of the instrument.

If incorrect measurements occur, contact a qualified service technician.

**Conductivity
model
coefficient**

The conductivity model coefficient is based on a 2-point calibration. A straight line is drawn through two points of a TOC-conductivity diagram. One point is measured with dilution water, the other point is measured with calibration standard. It is assumed that the TOC content is approximately proportional to the increase of conductivity caused by oxidation.

During the on-line measurement and the calibration, the sample is kept at a constant temperature of 42–43 °C. Therefore normally it is not necessary to consider the temperature dependence for calculating the TOC content of the sample.

Under certain conditions, however, it may be necessary to alter the percent value of the coefficient.



2.2. Verification

Note: A verification can be carried out only if the measuring mode "Pharma" is selected.

The AMI-II LineTOC is calibrated at the factory. Since the accuracy of TOC measurements depends directly on the calibration of the instrument, it is recommended to verify the calibration at regular intervals (see [Maintenance Schedule, p. 43](#)). The calibration parameters are verified by measuring a standard solution with a known TOC concentration. A verification of the instrument calibration is required by international regulations such as USP and EP.

To verify the slope of the calibration curve, the two solutions

- ◆ reagent water blank and
- ◆ standard solution 1 ppm C as sucrose

are measured in sequence. The result is a deviation in percent. The range from 0 to 1'000 ppb TOC corresponds to the requirements for monitoring pure and ultrapure water with a maximum conductivity of 2 $\mu\text{S}/\text{cm}$.

2.3. Calibration

Note: A calibration can be carried out only if the measuring mode "UPW" and the conductivity model "Coefficient" are selected.

The AMI-II LineTOC is calibrated at the factory. Since the accuracy of TOC measurements depends directly on the calibration of the instrument, it is recommended to calibrate at regular intervals (see [Maintenance Schedule, p. 43](#)). The calibration parameters are determined by measuring a standard solution with a known TOC concentration.

To determine the slope of the calibration curve the two solutions

- ◆ reagent water blank
- ◆ standard solution 1 ppm C as sucrose

are measured in sequence. The result of these two measured values can be used to recalculate the slope of the calibration curve in ppb/nS.

The calibration curve specifies the conversion between the content of carbon in the sample (or standard) and the reading of the instrument as conductivity difference. The calibration range from 0 to 1'000 ppb TOC corresponds to the requirements for monitoring pure and ultrapure water with a maximum conductivity of 2 $\mu\text{S}/\text{cm}$. If required, standard solutions with lower TOC concentration can be programmed by the user in the instrument firmware.

2.4. System Suitability Test for Pharma

The AMI-II LineTOC analyzer is designed to meet the requirements of the USP and EP for monitoring of pharmaceutical water. A qualification of the instrument according to the European and American pharmacopoeia requires a regularly performed system suitability test (SST) to verify the performance of the system.

The measurements of two different standards with

- ♦ reagent water blank [2]
- ♦ 500 ppb C as sucrose standard solution [3]
- ♦ 500 ppb C as 1,4-benzoquinone SST solution [4]

are compared. The reagent water blank [2] is used to prepare the standard and SST solutions. It is measured first to determine its TOC content. This TOC content is then subtracted from the TOC content of the standard solutions during the SST. The two organic compounds sucrose and 1,4-benzoquinone differ in their UV stability. Sucrose is easier to oxidize than 1,4-benzoquinone. The system suitability test checks the oxidation performance of the analyzer by measuring the response efficiency of the two reference standard solutions.

The system is suitable if the response efficiency is not less than 85% and not more than 115%.

Definitions

SST	System Suitability Test
Limit response	Measured TOC concentration of the standards solution corrected by the reagent water blank
R_S	Standard response (TOC concentration)
R_{SS}	System suitability response (TOC concentration)
R_W	Water response (TOC reagent water blank)
Response efficiency	<p>Calculated quotient of the standard and test solution concentrations, corrected by the reagent water blank.</p> $\text{Response efficiency (\%)} = \frac{R_{SS} - R_W}{R_S - R_W} \times 100\%$



2.5. Fluidics Overview

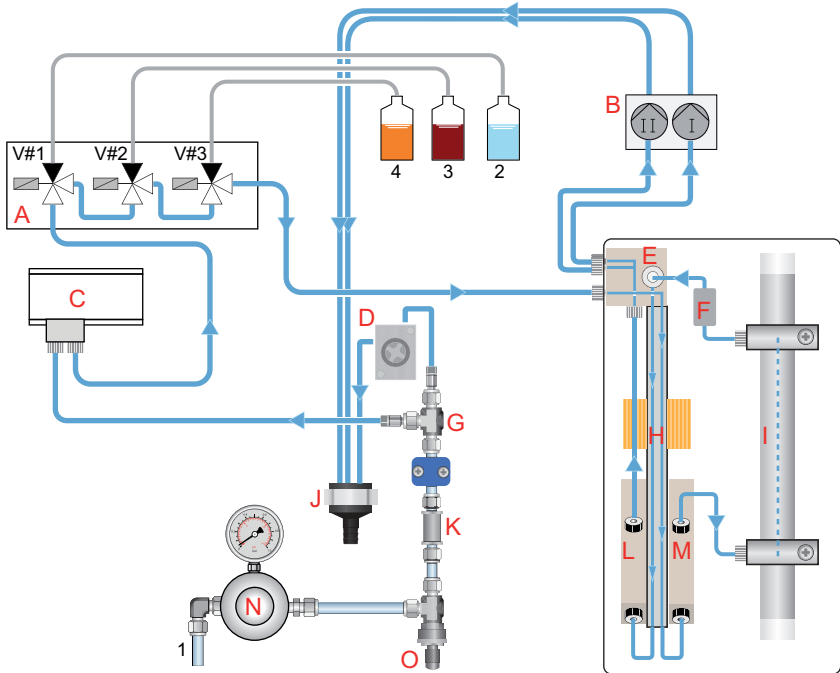

- | | |
|--|--|
| 1 Sample inlet | G Sample overflow |
| 2 Bottle holder Pos.2 ¹⁾ | H Heating element |
| 3 Bottle holder Pos.3 ¹⁾ | I UV reactor |
| 4 Bottle holder Pos.4 ¹⁾ | J Drain funnel |
| A Valve block | K Check valve |
| B Peristaltic pump | L Conductivity sensor 2 |
| C Sample cooler (optional) | M Conductivity sensor 1 |
| D Flow meter | N Pressure regulator (optional) |
| E Reactor port | O Flow regulating valve |
| F Flow monitoring sensor | |

¹⁾see [Assignment of standard solutions to bottle holders](#); p. 15.

Fluidics To avoid contamination of the sample with the pump tubing material, the sample is sucked through the system via channels I and II of the peristaltic pump [B].

The sample enters the system at the sample inlet [1]. Optionally a pressure regulator [N] can be installed to keep the inlet pressure constant. Excess sample is directed into the drain funnel [J]. The flow quantity can be adjusted with the flow regulating valve [O]. In on-line mode the sample is sucked via the valve block [A] and the heating element [H] through the conductivity sensor 1 [M] where the first measurement is carried out. Then the sample flows through the UV reactor [I] where the organic carbon is converted into carbon dioxide by oxidation. After oxidation, the sample flows via flow monitoring sensor [F] through the conductivity sensor 2 [L] where a second conductivity measurement is carried out.

Finally the sample flows through the peristaltic pump [B] and into the drain funnel [J].

Flow monitoring Flow meter [D] measures the sample flow at the overflow. In addition, the temperature of the sample after the UV reactor is measured via the sensor [F] and compared with the housing temperature. This allows to monitor the correct function of the peristaltic pump and the heating element.

If sample flow through the reactor is too low, the UV reactor, the heating element and the peristaltic pump are switched off automatically.

QA routines The solenoid valves [A] are used to perform the various tests and controlled by the transmitter.

The pharmaceutical industry and the ultra pure water (UPW) applications use different bottle setups and concentrations, see table below.

Assignment of standard solutions to bottle holders:

Bottle holder	Pharma	UPW
Pos. 2	Reagent water blank or grab sample	Reagent water blank or grab sample
Pos. 3	Standard solution 500 ppb C as sucrose	Standard solution (programmable value)
Pos. 4	SST solution 500 ppb C as 1,4-benzoquinone	Not used



2.6. Instrument Specification

Power supply	AC variant:	100–240 VAC ($\pm 10\%$) 50/60 Hz ($\pm 5\%$) DC variant not available
	Power consumption	max. 55 VA
Transmitter specifications	Housing:	aluminum, with a protection degree of IP 66 / NEMA 4X
	Ambient temperature:	-10 to +50 °C
	Humidity:	10–90% rel., non condensing
	Display:	backlit LCD, 74 x 53 mm
Measuring range	Range	Resolution
	0.00 to 9.99 ppb	0.01 ppb
	10.0 to 99.9 ppb	0.1 ppb
	100 to 999 ppb	1 ppb
Reproducibility	Range	Reproducibility
	0.1 to 50 ppb	± 1 ppb
	50 to 1000 ppb	$\pm 2\%$
Accuracy conductivity	Range	Accuracy
	0.055 to 2 $\mu\text{S}/\text{cm}$ (25 °C)	$\pm 1\%$
Sample requirements	Flow rate:	3–6 l/h
	Temperature:	10–40 °C
	<i>*with sample cooler:</i>	up to 90 °C
	Inlet pressure _{Abs} :	up to 1.5 bar
	<i>*with pressure regulator and sample cooler:</i>	up to 5 bar, 80 °C
	Outlet pressure:	pressure free
	Conductivity range:	0.055 to 2 $\mu\text{S}/\text{cm}$
	Particle size:	<100 μm
	No sand, no oil.	
	On-site requirements	The analyzer site must permit connections to:
Sample inlet:	Swagelok 1/4" tube adapter	
Sample outlet:	for flexible tube inner diameter 15 mm	
	If the sample temperature is higher than 40 °C, the sample has to be cooled before measurement.	
	<i>*Option</i>	

AMI-II LineTOC

Product Description

Dimensions (version on vertical panel)

Panel:	stainless steel
Dimensions:	400 × 850 × 200 mm
Screws:	8 mm
Weight:	20 kg

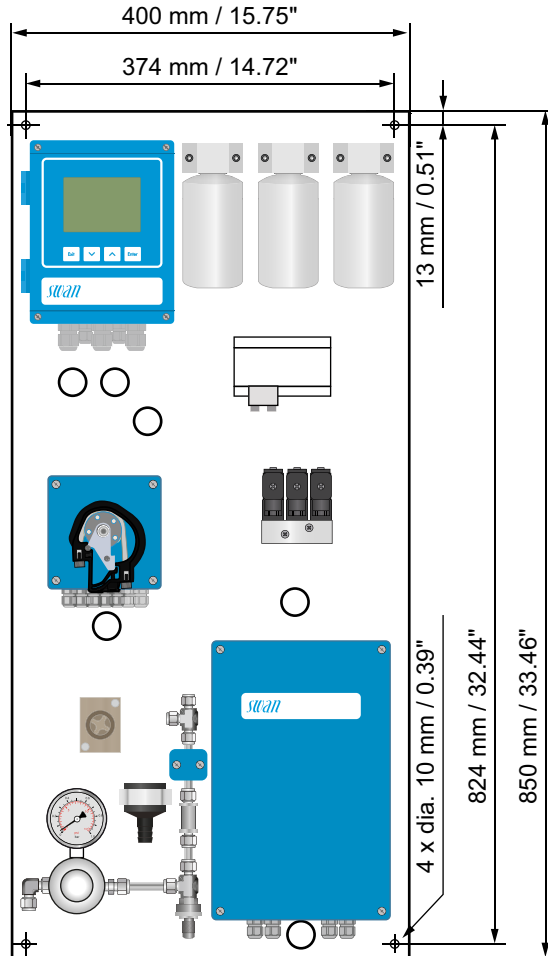

Dimensions (version on horizontal panel)	Panel:	stainless steel
	Dimensions:	700 × 450 × 200 mm
	Screws:	8 mm
	Weight:	20 kg

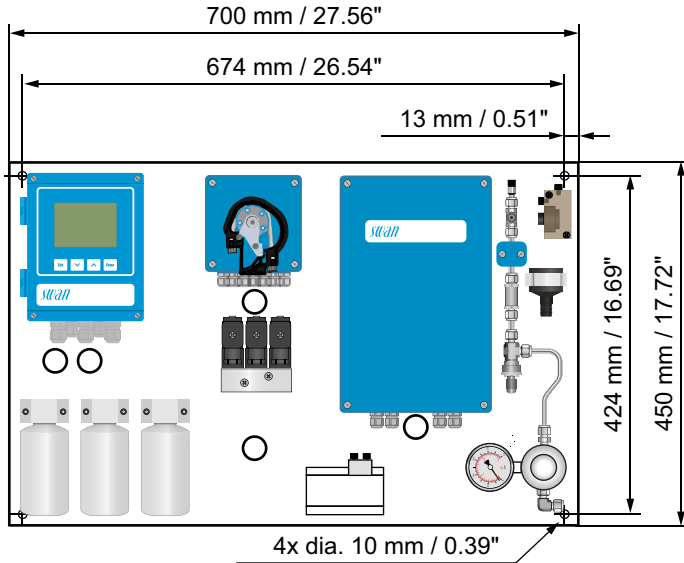

2.7. Instrument Overview

Version on
 vertical panel

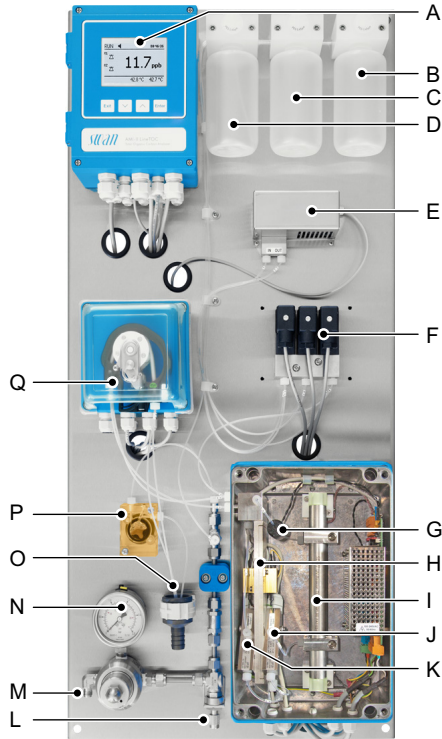

- | | |
|---|---|
| A Transmitter | J Conductivity sensor 1 |
| B Bottle holder Pos. 2 ¹⁾ | K Conductivity sensor 2 |
| C Bottle holder Pos. 3 ¹⁾ | L Flow regulating valve |
| D Bottle holder Pos. 4 ¹⁾ | M Sample inlet |
| E Sample cooler | N Pressure regulator with manometer (option) |
| F Valve block | O Waste |
| G Temperature sensor for flow monitoring | P Flow meter |
| H Heating element | Q Peristaltic pump |
| I UV reactor | |

¹⁾ see [Assignment of standard solutions to bottle holders](#); p. 15.

**Version on
 horizontal
 panel**

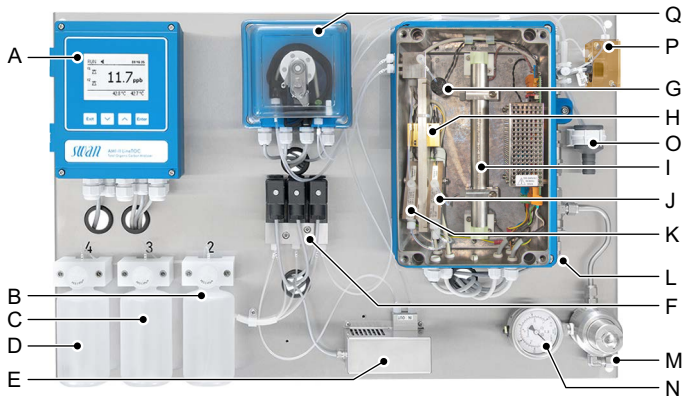

- | | |
|--|--|
| A Transmitter | J Conductivity sensor 1 |
| B Bottle holder Pos. 2 ¹⁾ | K Conductivity sensor 2 |
| C Bottle holder Pos. 3 ¹⁾ | L Flow regulating valve |
| D Bottle holder Pos. 4 ¹⁾ | M Sample inlet |
| E Sample cooler | N Pressure regulator with
manometer (option) |
| F Valve block | O Waste |
| G Temperature sensor for flow
monitoring | P Flow meter |
| H Heating element | Q Peristaltic pump |
| I UV reactor | |

¹⁾ see [Assignment of standard solutions to bottle holders](#); p. 15.

3. Installation

3.1. Installation Checklist

On-site requirements	Voltage: 100–240 VAC ($\pm 10\%$), 50/60 Hz ($\pm 5\%$). Power consumption: 55 VA maximum. Protective earth connection required. Sample line with at least 3 l/h. Sample outlet with pressure free drain.
Installation	Mount the instrument in vertical position. Display should be at eye level. Connect sample inlet and outlet.
Electrical wiring	Connect all external devices according to the connection diagram (p. 24). Connect power cord.
Standard and stock solutions	Prepare all necessary standard solutions and screw them onto the respective bottle holders.
Power up	Open the sample tap and adjust the sample flow to 3–6 l/h. If the optional pressure regulator is installed, set the input pressure to 0.2 bar. Switch on power.
Instrument setup	Set the measuring mode to UPW or Pharma. UPW: Set the compensation model to coefficient or CO ₂ . Program all parameters for external devices (interface, etc.). Program all parameters for instrument operation (limits, alarms).
Fill system	Start “Fill system” in Maintenance > Service .
Run-in period	Let instrument operate for 4 h without interruption at normal sample conditions to rinse out any pollution from transport and manufacturing.
Verification	Once the run-in time is over and the measured value is stable, perform a verification.



3.2. Mounting the Instrument

Mounting requirements

Mount the instrument in vertical position. The display should be at eye level to simplify operation and maintenance. The instrument is intended for indoor installation.

Dimensions

For dimensions, see [p. 17](#) and [p. 18](#).

3.3. Connect Sample and Waste

Sample inlet

Use a tube made of a suitable material, e.g. SS 316L, PTFE or FEP, to connect the sample line.

Mounting of Swagelok fitting

Insert the tube into the Swagelok fitting. Make sure that the tube rests firmly on the shoulder of the fitting and the nut is finger-tight. While holding the fitting body steady with a backup wrench, tighten the nut 1 1/4 turns.

Waste

Connect a tube to the hose nozzle [C] of the drain funnel [B] and place it into a pressure free drain of sufficient capacity.

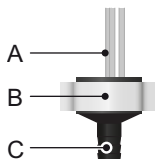

- A** Tubes from overflow and from peristaltic pump
- B** Drain funnel
- C** Hose nozzle

3.4. Electrical Connections



WARNING

Risk of electrical shock

Failure to follow safety instructions can result in serious injury or death.

- ♦ Always turn off power before manipulating electric parts.
- ♦ Do not connect the instrument to power unless the ground wire (PE) is connected.
- ♦ Make sure the power specification of the instrument corresponds to the power on site.

Cable thicknesses

In order to comply with IP66, use the following cable thicknesses. Protect unused cable glands.

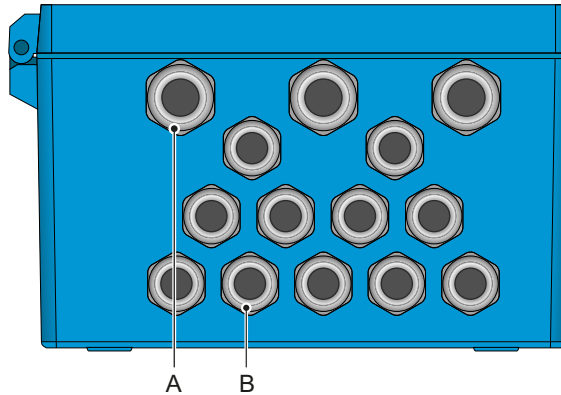

A M16 cable glands (3x): cable \varnothing_{outer} 5–10 mm

B M12 cable glands (11x): cable \varnothing_{outer} 3–6 mm

Wires

For power and relays: Use max. 1.5 mm² / AWG 14 stranded wire with end sleeves.

For signal outputs and input: Use 0.25 mm² / AWG 23 stranded wire with end sleeves.



3.4.1 Power Supply

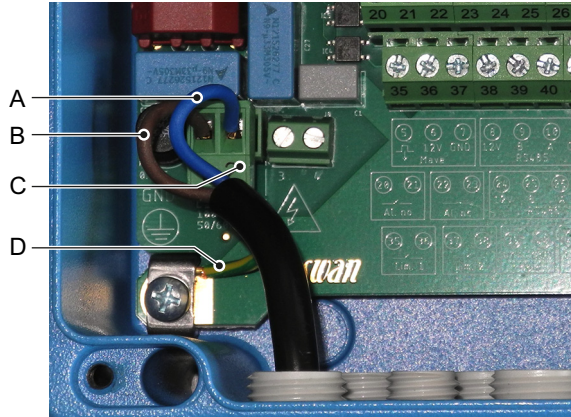

- A** Neutral conductor, terminal 2
- B** Phase conductor, terminal 1
- C** Power supply connector
- D** Protective earth PE

Installation requirements

The installation must meet the following requirements.

- ♦ Mains cable according to standards IEC 60227 or IEC 60245; flammability rating FV1.
- ♦ Mains equipped with an external switch or circuit-breaker
 - near the instrument
 - easily accessible to the operator
 - marked as interrupter for AMI-II LineTOC

3.5. Relay Contacts

3.5.1 Input

Use only potential-free (dry) contacts.
Terminals: 39/40

3.5.2 Alarm Relay

Two alarm outputs for system errors.

- ♦ Normally closed contact (terminals: 22/23):
Active (opened) when no error is present. Inactive (closed) on error and loss of power.
- ♦ Normally open contact (terminals: 20/21):
Active (closed) when no error is present. Inactive (opened) on error and loss of power.

Max. load 100 mA/50 V resistive

3.5.3 Relay 1 and 2

Max. load 100 mA/50 V resistive
Relay 1: terminals 35/36.
Relay 2: terminals 37/38.

3.6. Signal Outputs

3.6.1 Signal Output 1 and 2 (Current Outputs)

Max. burden 510 Ω .

If signals are sent to two different receivers, use signal isolator (loop isolator).

Signal output 1: Terminals 17 (+) and 16 (-)

Signal output 2: Terminals 18 (+) and 16 (-)

3.7. Interface Options

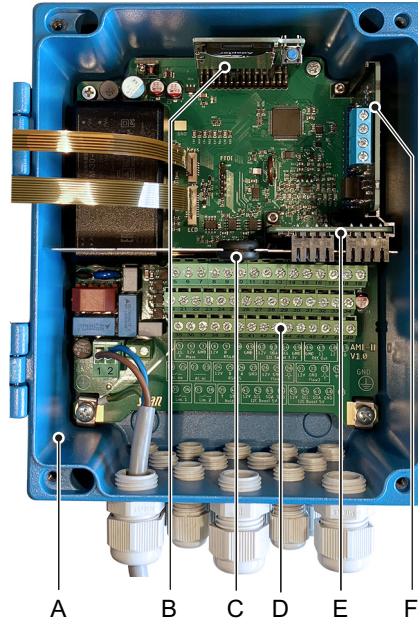

- A* AMI-II transmitter
- B* SD card slot
- C* Cable grommet
- D* Screw terminals
- E* Frontend
- F* Communication option

The slot for interfaces can be used to expand the functionality of the AMI-II transmitter with either:

- ◆ Two additional signal outputs
- ◆ Profibus or Modbus
- ◆ HART

3.7.1 Signal Outputs 3 and 4

Max. burden 510 Ω .

If signals are sent to two different receivers, use signal isolator (loop isolator).

Signal output 3: terminals 71 (+) and 70 (-).

Signal output 4: terminals 73 (+) and 72 (-).

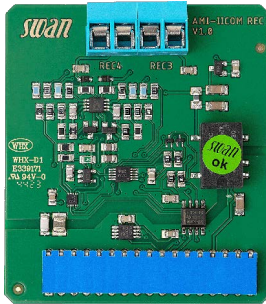

3.7.2 RS485 (Profibus or Modbus Protocol)

Terminal 74/75 PB, terminal 70/71 PA, terminal 72/73 shield

The switch [A] must be set to "ON" if only one instrument is installed or on the last instrument in the bus.

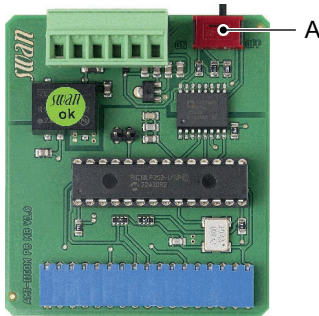

A On/off switch

3.7.3 HART

Terminals 71 (+) and 70 (-).

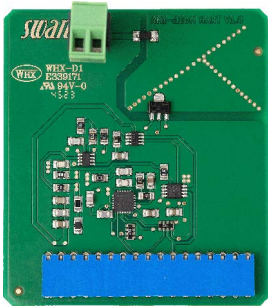

4. Instrument Setup

4.1. Standard and Stock Solutions

Handling of TOC solutions

The standard solutions for verification, calibration, and SST for the AMI-II LineTOC are not preserved due to the measuring principle of the instrument. The solutions therefore have a limited shelf life of a few weeks to months, depending on the manufacturer. Please contact your manufacturer of standard solutions for individual specifications and order shortly before use, taking into account the expected delivery times. Prepare fresh standard solutions for each application if you produce them yourself. In general, the standard solutions must be kept refrigerated at a maximum of 5 °C.

4.2. Peristaltic Pump

The instrument is delivered with opened occlusion frames. Close the occlusion frames [B].

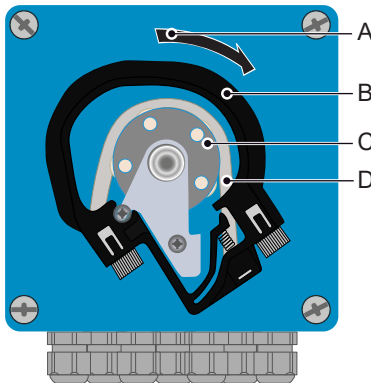

- A** Turn to lock
- B** Occlusion frame
- C** Rotor
- D** Pump tube

4.3. Establish Sample Flow

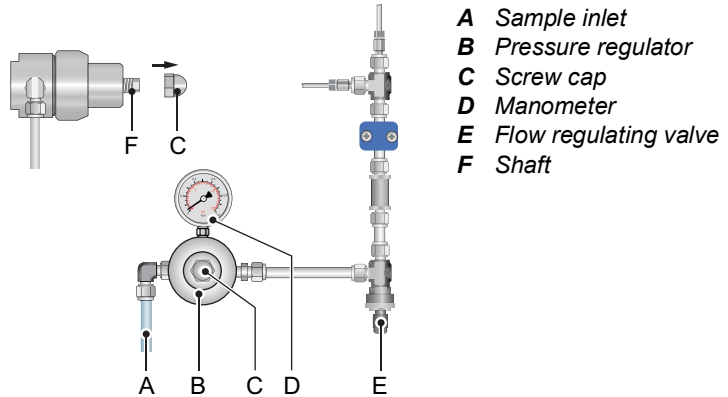

- 1 If a pressure regulator [B] is installed set the input pressure to 0.2 bar. Proceed as follows:
 - Unscrew and remove the screw cap [C] with a 17 mm open end wrench.
 - Adjust the inlet pressure to 0.2 bar by turning the shaft [F] with a 7 mm open end wrench.
- 2 Open the flow regulating valve [E].
- 3 Switch on power.
- 4 Navigate to menu **Maintenance > Service > Fill System** and press [Enter].
⇒ *The peristaltic pump starts and all tubes are filled.*

4.4. Programming

- Pharma** For pharmaceutical applications, set the operation mode to Pharma. This will automatically set the compensation model to CO₂.
- UPW** For UPW applications set the instrument to:
- ♦ operation mode: UPW
 - ♦ compensation model: either CO₂ or coefficient according to your requirements. See [Conductivity model CO₂, p. 10](#) and [Conductivity model coefficient, p. 11](#).
- General** Program all parameters for external devices (interface, etc.) and all parameters for instrument operation (limits, alarms). See [Program List and Explanations, p. 68](#) for details.

4.5. Commissioning

- Standard solutions** Prepare all necessary standard solutions and screw them onto the respective bottle holders. See [Assignment of standard solutions to bottle holders;](#), p. 15.
- Run-in period** Let the instrument run in for 4 hours on normal sample conditions to flush out contaminants caused by manufacturing and transport.
- Pharma** Perform a system suitability test and a verification.
- UPW** Perform a calibration.
- IQ/OQ/PQ** If the optional validation package for pharmaceutical applications has been ordered, proceed as described in the IQ/OQ/PQ documents.

5. Operation

5.1. Keys

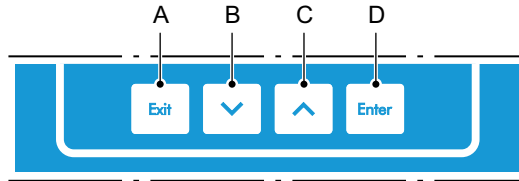

- A** to exit a menu or command (rejecting any changes)
to move back to the previous menu level
- B** to move down in a menu list and to decrease digits
- C** to move up in a menu list and to increase digits
to switch between display 1 and 2
- D** to open a selected menu item
to accept an entry

Program access, exit

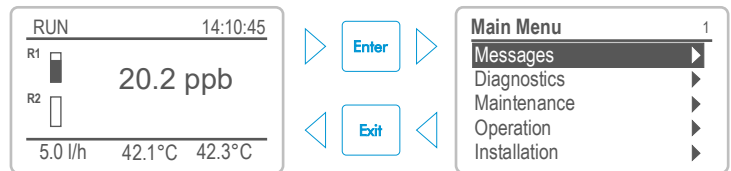

5.2. Display

Display
(conductivity
model CO₂)

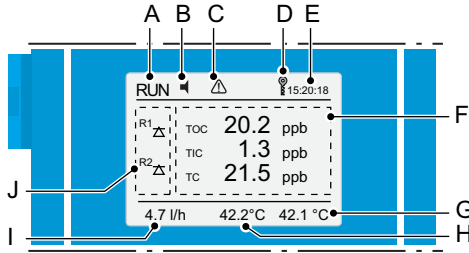

Display
(conductivity
model
coefficient)

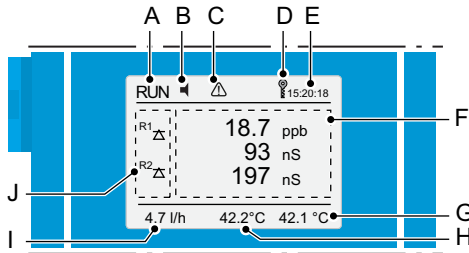

- A** RUN Normal operation
- HOLD Input active or cal delay: Instrument on hold (shows status of signal outputs)
- OFF Input active: Signal outputs go to 0/4 mA.
- B** Error ◀ Non-fatal error ⚠ Fatal error
- C** See maintenance list for detailed information
- D** Transmitter control via Profibus
- E** Time
- F** Process values (conductivity model CO₂ in ppb, conductivity model coefficient in nS)
- G** Sample temperature at reactor output
- H** Sample temperature at reactor input
- I** Sample flow
- J** Relay status

Note: Changing the percent value Coefficient in the menu *Installation > Sensors > TOC > Measurement > Compensation* has an effect on the values displayed as process values [F] in the conductivity model Coefficient. These values are converted to a reference temperature of 25 °C and compensated with the preset percent value of the Coefficient. It has no effect on the values displayed in the menu *Diagnostics > Sensors*. These are the uncompensated values measured at the current sample temperature.







Switch between display 1 and 2 with the  key.



A Display 1

B Display 2

Symbols used
 for relay status

-   Upper/lower limit not yet reached
-   Upper/lower limit reached
-  Relay inactive (controlled via fieldbus)
-  Relay active (controlled via fieldbus)

5.3. Software Structure

Main Menu	1
Messages	▶
Diagnostics	▶
Maintenance	▶
Operation	▶
Installation	▶

Messages	1.1
Pending Errors	▶
Maintenance List	▶
Message List	▶
Audit Trail	▶

Menu 1 Messages

Shows pending errors as well as the event history (time and state of events that have occurred at an earlier point of time).
Contains user-relevant data.

Diagnostics	2.1
Identification	▶
Sensors	▶
Sample	▶
I/O State	▶
SD Card	▶

Menu 2 Diagnostics

Provides user-relevant instrument and sample data.

Maintenance	3.1
Verification	▶
Suitability Test	▶
Service	▶
Set Time	23.09.06 16:30:00

Menu 3 Maintenance

For instrument calibration, relay and signal output simulation, and to set the instrument time.
Used by service personnel.

Operation	4.1
Grab Sample	▶
Sensors	▶
Logger	▶

Menu 4 Operation

User-relevant parameters that might need to be modified during daily routine. Normally password protected and used by the process operator.
Subset of menu 5 - Installation, but process related.

Installation	5.1
Sensors	▶
Signal Outputs	▶
Relay Contacts	▶
Miscellaneous	▶
Interface	▶

Menu 5 Installation

For initial instrument set up by Swan authorized person.
Password protection strongly recommended.

5.4. Changing Parameters and Values

Changing parameters

The following example shows how to change the logger interval:

Logger	4.4.1
Log interval	30 min
Clear logger	no
Eject SD Card	<Enter>

Logger	4.1.3
Log interval	Interval. ↓
Clear log	5 min
Eject SD	10 min
	30 min
	1 Hour

Logger	4.1.3
Log interval	10 min
Clear logger	no
Eject SD Card	<Enter>

Logger	4.1.3
Log interval	Save ?
Clear log	no
Eject SD	Yes
	No
	Enter>

- 1 Select the parameter you want to change.
- 2 Press [Enter].
- 3 Press ▲ or ▼ to highlight the required parameter.
- 4 Press [Enter] to confirm the selection or [Exit] to keep the previous parameter).

⇒ *The selected parameter is highlighted (but not saved yet).*

- 5 Press [Exit].

⇒ *Yes is highlighted.*

- 6 Press [Enter] to save the new parameter.

Changing values

Alarm	5.3.1.1.1
Alarm High	2.00 ppm
Alarm Low	0.60 ppb
Hysteresis	10.0 ppb
Delay	30 Sec

Alarm	5.3.1.1.1
Alarm High	900 ppb
Alarm Low	0.60 ppb
Hysteresis	10.0 ppb
Delay	30 Sec

- 1 Select the value you want to change.
- 2 Press [Enter].
- 3 Set required value with ▲ or ▼.
- 4 Press [Enter] to confirm the new value.
- 5 Press [Exit].
⇒ *Yes is highlighted.*
- 6 Press [Enter] to save the new value.

5.5. Data Logger

Overview The instrument has an integrated data logger. The following data is recorded:

Data type	Number of data sets in internal buffer	Elements of each data set
Event history	64	Error messages with date, time, code, description and state (active, acknowledged, cleared).
Audit Trail	256	Menu calls with date, time and user name.
Verification history	64	Verifications with date, time, standard value, measured value and deviation.
System suitability test (SST) history	64	System suitability tests with date, time, efficiency, TOC concentrations of sucrose and benzoquinone standards and dilution water.
Grab sample history	64	Grab sample measurements with date, time, sample ID and measured TOC concentration.
Measured values	approx. 1500	Measured values with date, time, active alarms, measured values and sample flow rate.

The data is stored in an internal buffer per data type. As soon as a buffer is full, the oldest data set is deleted to make room for the newest data set (circular buffer).

The contents of the internal buffers can be copied to an SD card at any time.

Limitations The data is only written to the SD card when the SD card is ejected. The amount of available data records is therefore limited to the size of the internal buffers.

An exception is the logging of measured values: If the SD card is inserted, measured values are also written directly to the SD card in parallel with storage in the internal buffer.

Writing data to SD card

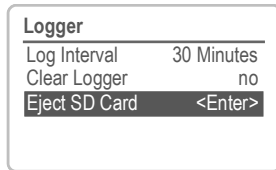
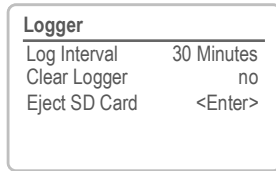
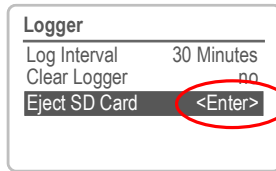

- 1 Select **Operation > Logger > Eject SD Card**.

⇒ While the data is being written to the SD card, the gray background of the “Eject SD Card” menu item disappears.

- 2 Remove the SD card as soon as the background of the Eject SD Card menu item is gray again.
 - 3 Copy the log files to a another medium for permanent storage.
- !** Any log files already present on the SD card will be overwritten the next time the SD card is ejected.

Contents of the SD card (pharma mode)

After removing the SD card, the following files can be found on it:

- ◆ Audit Trail: TOCADT.SEF.
- ◆ Event history: TOCEVT.SEF.
- ◆ Grab sample history: TOCGRB.SEF.
- ◆ System suitability test history: TOCSST.SEF.
- ◆ Verification history: TOCVFY.SEF.
- ◆ Measured values:
 - A2TOC_I.TXT: Data from internal buffer.
 - A2TOC.TXT: Data written directly to SD card.
 - A2TOC[number].TXT: Archived version of A2TOC.TXT. The file is automatically archived and a new instance of it created, for example, when the SD card is ejected and reinserted.

Files with the extension *.sef are encrypted text files. These can be converted into signed PDF files using the SwanGuard program.

**Contents of
the SD card
(UPW mode)**



After removing the SD card, the following files can be found on it:

- ◆ Calibration history: CALTOC.TXT.
- ◆ Event history: EVTTOC.TXT.
- ◆ Grab sample history: GRBTOC.TXT.
- ◆ Measured values:
 - A2TOC_I.TXT: Data from internal buffer.
 - A2TOC.TXT: Data written directly to SD card.
 - A2TOC[number].TXT: Archived version of A2TOC.TXT. The file is automatically archived and a new instance of it created, for example, when the SD card is ejected and reinserted.

5.6. Grab Sample

The grab sample mode is used for measurements of samples which can not be connected to the sample inlet. The sample is filled into a bottle which is screwed into the sample holder on position 2.

To start a grab sample measurement proceed as follows:

- 1 Navigate to menu **Operation > Grab Sample**.
⇒ *You will be prompted to enter a name for the sample. The name can be a maximum of 8 characters.*
- 2 Press [Enter].
⇒ *A cursor appears under the first digit.*
- 3 Press the  or  to select a character.
- 4 Press [Enter].
⇒ *The next digit is active.*
- 5 Repeat step 3 and 4 until the name is entered.
- 6 If the name is shorter than 8 digits press [Enter] until the cursor has passed the last digit.
- 7 Press [Enter] to start the grab sample measurement.



6. Maintenance

Some countries have found national regulations on surveillance of analyses. In case no such regulations are applicable, you will find recommendations below.

General information on the following test procedures:

- ♦ Verification
- ♦ Calibration
- ♦ SST

The duration of a test procedure depends on the stability of the measured value. If the measured value is stable over a certain time, the test procedure can be finished by pressing [Enter] and the measured value is saved.

If required the duration can be shortened manually after a minimal time of 5 minutes. Be aware that thereby the stability criteria of the measured value are ignored.

Swan recommends to use the automatic standard measuring procedure of the AMI-II LineTOC.

6.1. Maintenance Schedule

Pharma applications

Every week	Check sample flow.
Half-yearly	Perform system suitability test, see p. 47 . Replace UV reactor and perform verification, see p. 53 and p. 44 . Replace pump tubing, see p. 48 .
Yearly	Replace air filters (3 pcs.), see p. 56 .

UPW applications

Every week	Check sample flow.
Every 9 to 12 months	Replace UV reactor, see p. 53 .
Yearly	Replace pump tubing, see p. 48 . Replace air filters (3 pcs.), see p. 56 . If necessary, perform a calibration, see p. 46 .



6.2. Stop of Operation for Maintenance

Before starting any maintenance work, all tubes as well as the UV reactor have to be emptied. To empty the system, proceed as follows:

- 1 Close the tap of the sample inlet.
- 2 Select “Exchange Lamp” in menu **Maintenance** > **Service** > **Lamp**.
⇒ *The peristaltic pump runs in reverse mode.*
- 3 Wait until the peristaltic pump stops.
- 4 Shut off power of the instrument.

6.3. Verification

Note:

- *The verification procedure is available if the measuring mode is set to “Pharma”.*

The verification of the AMI-II LineTOC is based on a two-point method. The lower end is given by the TOC concentration of reagent water (blank), the upper limit is fixed by the known concentration of a standard solution 1 ppm C as sucrose. During verification the slope of a straight line, based on the two measuring points, is calculated. According to the regulations of the USP and EP the TOC content of the reagent water (blank) has to be <100 ppb TOC.

Note:

- *Make sure that the standard has the expected TOC concentration of 1 ppm (= 1'000 ppb).*

- Reagents and fluidic** For a verification, screw the two bottles containing
- ♦ reagent water (blank) [2] and
 - ♦ standard solution 1 ppm C as sucrose [3]
- onto the bottle holder with the corresponding number.
Measured value 1: Reagent water (blank) [2] is sucked through the system and measured.
Measured value 2: Standard solution [3] is sucked through the system and measured.
- Procedure** To start the verification process, select **Maintenance > Verification**. At the end of the procedure the results are displayed. Press [Enter] to save the factor in the history or [Exit] to discard it.
The calculated factor shows the operator whether the verification of the AMI-II LineTOC is within the given limit. It does not replace the current factor and it has no influence on further measurements.
The verification history can be viewed in menu **Diagnostics > Sensors > History > Verification**.
- Note: The displayed deviation should be in a range of $\pm 15\%$.*
- Signal outputs, limits** During the verification the signal outputs are on hold by default and all programmed limits are inactive.



6.4. Calibration

Note:

- *The calibration procedure is available if the measuring mode is set to “UPW” and the conductivity model is set to “Coefficient”.*

The calibration of the AMI-II LineTOC is based on a two point method. The lower end is given by the TOC concentration of reagent water (blank), the upper limit is adjustable.

Reagents and fluidic

For a calibration screw the two bottles containing

- ♦ reagent water (blank) [2] and
- ♦ sucrose standard solution [3]

onto the bottle holder with the corresponding number. Make sure that the TOC concentration of the sucrose standard solution is equal to the programmed value and corresponds to the working range of 0 to 1'000 ppb TOC.

Procedure

To start the calibration process, select **Maintenance > Calibration**. At the end of the procedure the results are displayed. Press [Enter] to save the new calculated slope or [Exit] to discard it. The calibration history can be reviewed in menu **Diagnostics > Sensors > History > Calibration**.

Note: The displayed factor should be in a range of 0.3 and 1.8.

Signal outputs, limits

During the calibration, the signal outputs are on hold by default and all programmed limits are inactive.

6.5. System Suitability Test (SST)

The system suitability test is only available in the measuring mode "Pharma".

Reagents and fluidic

For this test screw the three bottles containing

- ♦ reagent/blank water [2],
- ♦ standard solution 500 ppb C as sucrose [3] and
- ♦ SST solution 500 ppb C as 1.4-benzoquinone [4]

onto the bottle holder with the corresponding number.

The reagent water blank [2] is sucked through sensors 1 and 2 via the reactor port and measured. This procedure is repeated with:

- ♦ standard solution 500 ppb C as sucrose [3] and
- ♦ SST solution 500 ppb C as 1.4-benzoquinone [4].

Procedure

The procedure of the system suitability test is menu-guided. According to the regulations of the USP and EP the standard and the SST solution have a certified TOC concentration of 500 ppb TOC. The TOC content of the reagent (dilution) water is <100 ppb TOC.

The system suitability test is started via the **Maintenance > Suitability Test** menu item.

Based on the measured TOC results of reagent water (blank) R_W , standard solution R_S and SST solution R_{SS} the instrument calculates the response efficiency as follows:

$$\text{Response efficiency (\%)} = \frac{R_{SS} - R_W}{R_S - R_W} \times 100\%$$

The test is successful if the response efficiency is within a range of 85 to 115%. Otherwise the system suitability test fails.

The history of the system suitability test can be reviewed. See **Diagnostics > Sensors > History > Suitability Test**.

Note:

- *In accordance with the regulations of USP and EP only certified (NIST traceable) standards must be used to perform the system suitability test.*
- *The reagent water blank for standard dilution is part of the system suitability standard set.*

Signal outputs, limits

During the System Suitability Test the signal outputs are on hold by default and all programmed limits are inactive.

6.6. Replace the Peristaltic Pump Tubes

Overview

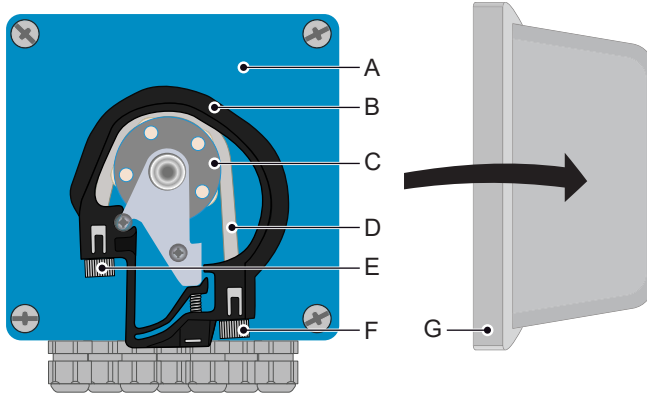

A Pump housing

B Occlusion frame closed

C Rotor

D Pump tube

E Pump inlet

F Pump outlet

G Protection cap

**Dismount
pump tubes**

The pump tubes can easily be dismounted and mounted. Proceed as follows:

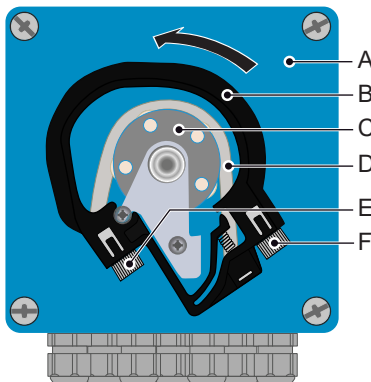

- A** Pump housing
- B** Occlusion frames relaxed
- C** Rotor
- D** Pump tubes
- E** Pump inlet
- F** Pump outlet

- 1 Switch off the instrument according to the instructions in [Stop of Operation for Maintenance, p. 44](#).
- 2 Remove the protection cap.
- 3 Open the occlusion frames [B] by turning them counter-clockwise.
- 4 Remove the pump tubes [D] from the rotor [C] by pulling the complete occlusion frames [B] out of the holder.
- 5 Disconnect the reagent tubes from the old pump tubes and connect them to the new pump tubes
- 6 Install the new pump tubes by pushing the occlusion frames onto the holder.
- 7 Lock the occlusion frames. Check that the occlusion frames and the tubes are aligned perpendicular to the axis of the rotor.
- 8 Start the "Fill system" function.



6.7. Tube Numbering

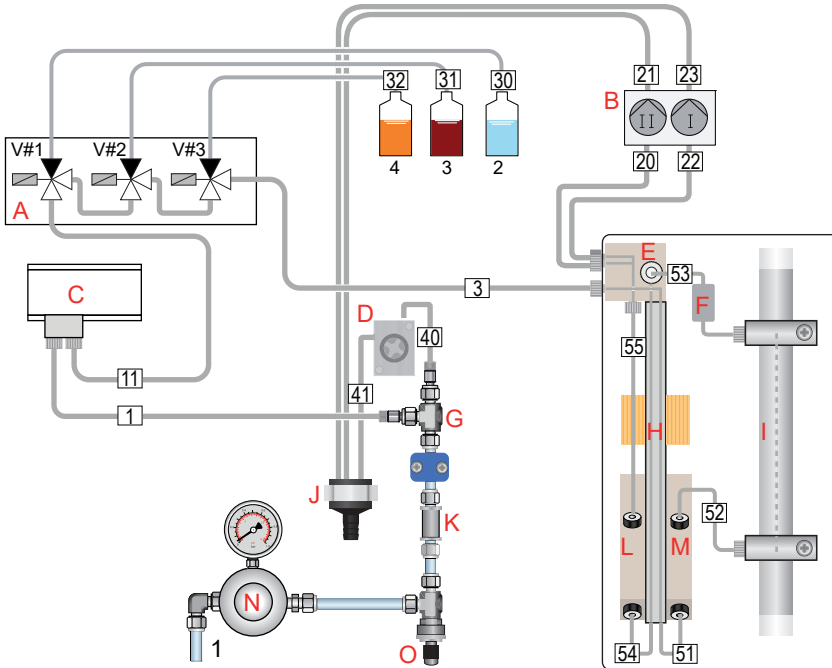

Tube no.	From	To
1	Sample overflow [G]	Valve block [A] or sample cooler [C] inlet (if installed)
40	Sample overflow [G]	Flow meter [D]
41*	Flow meter [G]	Drain funnel [J]
3	Valve block [A]	Reactor port [E]
11	If installed, sample cooler [C] outlet	Valve block [A]
20	Reactor port [E]	Peristaltic pump [B] inlet
21*	Peristaltic pump [B] outlet	Drain funnel [J]
22	Reactor port [E]	Peristaltic pump [B] inlet
23*	Peristaltic pump [B] outlet	Drain funnel [J]
30*	Reagent water blank (2) SST	Valve block [A]

Tube no.	From	To
31*	Standard solution 500 ppb C as sucrose (3)	Valve block [A]
32*	Solution 500 ppb C as 1.4-benzoquinone (4)	Valve block [A]
Tubes within reactor housing		
51	Heating element [H] out 1	Conductivity sensor 1 [M] in
52	Conductivity sensor 1 [M] out	UV reactor [I] in
53	UV reactor [I] out	Heating element in [H] via reactor port [E]
54	Heating element [H] out 2	Conductivity sensor 2 [L] in
55	Conductivity sensor 2 [N] out	Reactor port [E]

*Shorten to the appropriate length after laying.

**Connections
on valve
block**

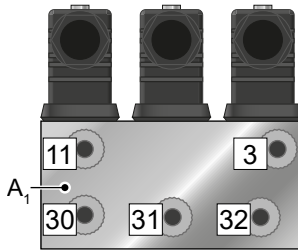

A₁ Valve block (view from below)

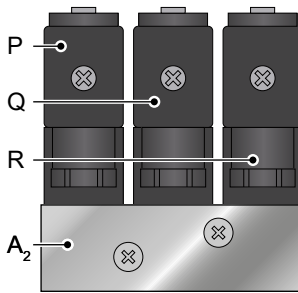

A₂ Valve block (front view)
P Valve 1
Q Valve 2
R Valve 3

**Connections
on reactor**

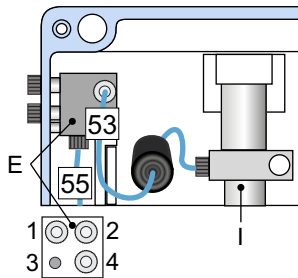

E Reactor port
I UV reactor

6.8. Replace the UV Reactor



WARNING

Electrical hazard

Risk of electrical shock caused by high ignition voltage.

- ◆ Disconnect main power supply before exchanging the UV reactor.

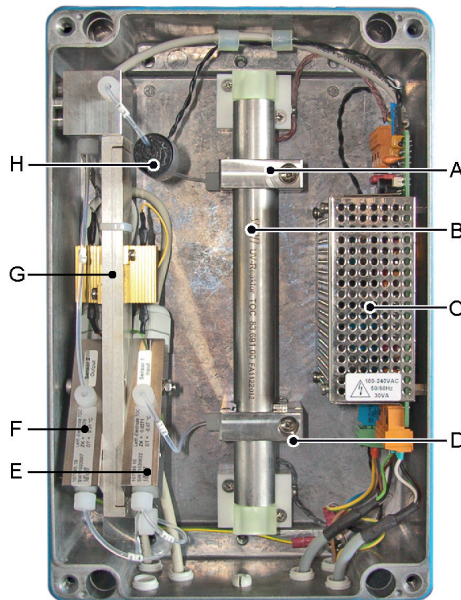

- A UV reactor holder neutral*
- B UV reactor*
- C Electric lamp ballast (EVG)*
- D Lower UV reactor holder (mechanically coded)*
- E Conductivity sensor 1*
- F Conductivity sensor 2*
- G Heating element*
- H Temperature sensor for flow monitoring*

Remove the UV reactor

1 Navigate to menu **Maintenance > Service > Lamp > Exchange Lamp**.

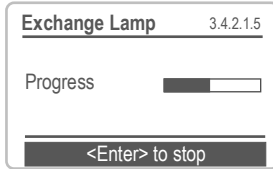

2 Press [Enter].
⇒ *The peristaltic pump runs in reverse mode to empty all tubes.*

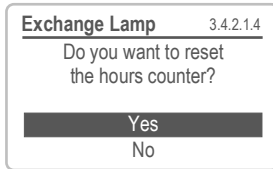

3 Press [Enter] to reset the counter or select "No" if you want to perform another maintenance task.

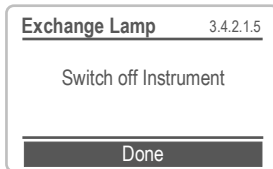

4 Press [Enter] to quit the menu.

5 Switch off the instrument.

6 Open the UV reactor case.

7 Unscrew both clamps of the reactor holders [A] and [D] and open them.

8 Remove the complete UV reactor form the reactor holders.

9 Remove the O-rings from the reactor holders.

UV radiation and recycling

Any radiation of the UV lamp (ozone-generating lamp) is absorbed by the polycarbonate cap of the complete UV reactor.

The UV lamp contains heavy metal (mercury). Therefore avoid breakage of glass and assure proper disposal (recycling).

Install the UV reactor

The replacement set for the UV reactor contains:

- ◆ 1 UV reactor
- ◆ 2 O-rings 1.78 x 1.78 mm

The guide plate [I] on the lower UV reactor holder [D] ensures together with the positioning pin [K] on the UV reactor, that the UV reactor can only be installed in one position. The guide hole [L] on the lower UV reactor holder ensures the precise alignment of the UV reactors sample input and output with the O-rings [M].

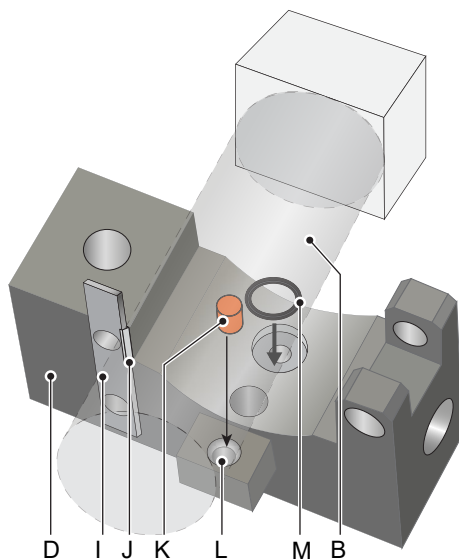

- D** UV reactor holder
- I** Guide plate
- J** Groove
- K** Positioning pin
- L** Guide hole
- M** O-ring
- B** UV reactor

- 1 Put the O-rings [M] into the bores (sample inlet and outlet) of the reactor holders [A] and [D].
- 2 Install the new UV reactor so that the guide plate [I] slides into the groove [J] of the UV-reactor and the positioning pin [K] slides into the guide hole [L].
- 3 Carefully push the UV reactor into the contact sockets.
- 4 Close the clamps of the reactor holders and tighten the screws.
- 5 Switch ON main power.
- 6 Start "Fill System" in menu **Maintenance > Service**.
- 7 Check the UV reactor input and output for leakage.
⇒ After "Fill System" has been finished, the instrument switches automatically to measuring mode and the UV lamp is switched on.
- 8 If no leakage occurs and the UV lamp is on screw the cover onto the case.
- 9 Reset the hours counter.

6.9. Replace Air Filters

The air filters are located on the bottle holders. They prevent the standard solutions from contamination with particles via the air. Replace the air filters annually.

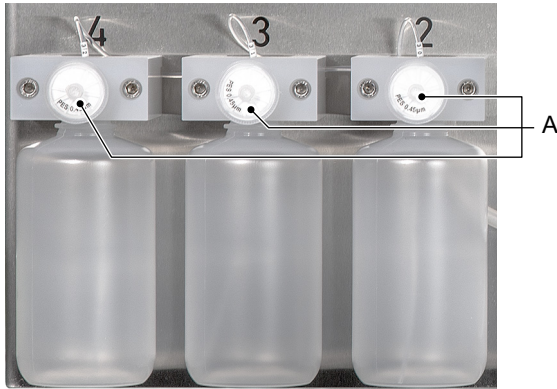

A Air filters

6.10. Longer Stop of Operation

- 1 Switch off the instrument according to the instructions in [Stop of Operation for Maintenance, p. 44](#).
- 2 Relax the occlusion frames of the peristaltic pump.



7. Troubleshooting

7.1. Error List

Two categories of messages are distinguished:

Non-fatal error ◀

Non-fatal instrument error or exceeding of a programmed limit value. Such errors are marked **E0xx** (bold and black) in the following list.

Fatal error (flashing symbol)

Fatal instrument error. Control is interrupted and the displayed measured values may not be correct.

Fatal errors are divided into the following two subcategories:

- ◆ Errors which disappear when correct measuring conditions are recovered (i.e. sample flow low). Such errors are marked **E0xx** (bold and orange) in the following list.
- ◆ Errors which indicate a hardware failure of the instrument. Such errors are marked **E0xx** (bold and red) in the following list.

Error	Description	Corrective action
E001	TOC Alarm high	– Check process. – Check programmed value.
E002	TOC Alarm low	– Check process. – Check programmed value.
E003	Cond. 1 Alarm high	– Check process. – Check programmed value.
E004	Cond. 1 Alarm low	– Check process. – Check programmed value.
E005	Cond. 2 Alarm high	– Check process. – Check programmed value.
E006	Cond. 2 Alarm low	– Check process. – Check programmed value.
E007	Temp. 1 Alarm high	– Check sample temperature. – Check heating element. – Check programmed value.
E008	Temp. 1 Alarm low	– Check sample temperature. – Check heating element. – Check programmed value.
E009	Sample Flow high	– Check inlet pressure. – Readjust sample flow.
E010	Sample Flow low	– Check inlet pressure. – Readjust sample flow.
E011	Temp. 1 shorted	– Replace sensor.
E012	Temp. 1 disconnected	– Check cable connection.
E013	Case Temp. high	– Check environment temperature.
E014	Case Temp. low	– Check environment temperature.
E015	Lamp	– Check for other errors. – Check lamp.
E016	deltaT	– Check peristaltic pump. – Check tube connections.
E018	Periclip	– Check cable connection.
E019	Temp.2 shorted	– Replace sensor.
E020	Temp.2 disconnected	– Check cable connection.



Error	Description	Corrective action
E021	Temp. 2 Alarm high	<ul style="list-style-type: none"> – Check sample temperature. – Check heating element. – Check programmed value.
E022	Temp. 2 Alarm low	<ul style="list-style-type: none"> – Check sample temperature. – Check heating element. – Check programmed value.
E023	EVG	– Call support.
E024	Input active	<ul style="list-style-type: none"> – Message informing that the relay input has been actuated. – Can be deactivated in menu Installation > Relay contacts > Input > Fault.
E026	IC LM75	– Hardware failure, call support.
E029	No flow	<ul style="list-style-type: none"> – Check inlet pressure. – Readjust sample flow.
E030	I2C Frontend	– Hardware failure, call support.
E031	Calibration Recout	– Call support.
E032	Wrong Front-End	– Call support.
E049	Power-on	– None, status message.
E050	Power-down	– None, status message.
E066	Exchange Lamp	– The maximum permissible operating time of the lamp has been reached. Exchange the lamp.

7.2. Replacing Fuses

When a fuse has blown, find out the cause and fix it before replacement. Use tweezers or needle-nosed pliers to remove the defective fuse.

Use original fuses provided by Swan only.

AMI-II transmitter

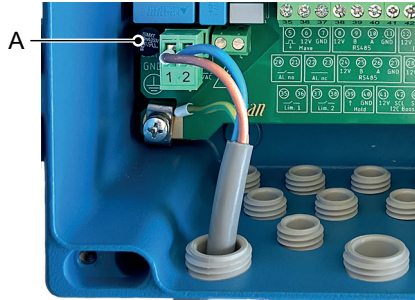

A 0.8 AT/250V Instrument power supply

8. Program Overview

All menus are password-protected as soon as an administrator password has been defined.

- ◆ Menu 1 **Messages** informs about pending errors and maintenance tasks and shows the error history. Access by administrator, service and operator. No settings can be modified.
- ◆ Menu 2 **Diagnostics**: Access by administrator, service and operator. No settings can be modified.
- ◆ Menu 3 **Maintenance**: Calibration, simulation of outputs and set time/date. Access by administrator and service.
- ◆ Menu 4 **Operation**: Allows to set limits, alarm values, etc. Access by administrator and service.
- ◆ Menu 5 **Installation**: Defining assignment of all inputs and outputs, measuring parameters, interface, passwords, etc. Access by administrator only.

8.1. Messages (Main Menu 1)

Pending Errors 1.1*	<i>Pending Errors</i>	1.1.5*
Maintenance List 1.2*	<i>Maintenance List</i>	1.2.5*
Message List 1.3*	<i>Message List</i>	1.3.1*
Audit Trail 1.4*	<i>Audit Trail</i>	1.4.1*

* Menu numbers

8.2. Diagnostics (Main Menu 2)

Identification	<i>Designation</i>	* Menu numbers
2.1*	<i>Version</i>	
	<i>Bootloader</i>	
Peripherals	<i>Peri2</i>	2.1.3.1*
2.1.3*	<i>EVG</i>	
Factory Test	<i>Motherboard</i>	2.1.4.1*
2.1.4*	<i>Front End</i>	
Operating Time	<i>Years, days, h, min, s</i>	2.1.5.1*
2.1.5*		
Sensors	Sensors	Current value 2.2.1.1*
2.2*	2.2.1*	Cond.1 and 2
		Temp.1 and 2
	History	Verification (CO2) 2.2.2.100*
2.2.2*		Calibration (Coefficient) 2.2.2.101*
		Suitability Test 2.2.2.2*
		Grab Sample 2.2.2.3*
	Miscellaneous	Case Temp. 2.2.3.1*
2.2.3*		
	Lamp	Hours counter 2.2.4.1*
2.2.4*		Last exchange
	EVG	State 2.2.5.1*
2.2.5*		Ambient Temp.
		Sample Temp.
		deltaT
		Limit
Sample	<i>Sample ID</i>	2.3.1*
2.3*	<i>Sample flow</i>	
	<i>[raw value]</i>	
I/O State	Relays	Alarm Relay 2.4.1*
2.4*		Relay 1
		Relay 2
		Input
	Signal Outputs	Signal Output 1
		Signal Output 2

SD Card
2.5*

State

* Menu numbers

Interface
2.6*

Protocol 2.5.1*

Device Address

(only with RS485
interface)

Baud rate

Parity

8.3. Maintenance (Main Menu 3)

Verification	<i>(Progress)</i>	<i>(only mode CO2)</i>	
3.1*			* Menu numbers
Calibration	<i>(Progress)</i>	<i>(only mode Coefficient)</i>	
3.1*			
Suitability Test	<i>(Progress)</i>	<i>(only Pharma)</i>	
3.20*			
Service	Simulation	<i>Relay 1/2</i>	3.30.1.1/2*
3.30*	3.30.1*	<i>Signal Output 1/2</i>	3.30.1.3/4*
	Lamp	<i>Exchange Lamp</i>	3.30.2.1*
	3.30.2*	<i>Reset hours counter</i>	3.30.2.2*
	Fill System	<i>(Progress)</i>	
	3.30.3*		
	Test Modules	<i>Lamp</i>	3.30.4.1*
	3.30.4*	<i>PeriClip</i>	3.30.4.2*
		<i>Solenoid Valve 1</i>	3.30.4.3*
		<i>Solenoid Valve 2</i>	3.30.4.4*
		<i>Solenoid Valve 3</i>	3.30.4.5*
	<i>DeltaT Cal.</i>	<i>(Progress)</i>	
	3.30.5*		
Set Time	<i>(Date, Time)</i>		
3.4*			

8.4. Operation (Main Menu 4)

Grab Sample	<i>Sample ID</i>	4.1*
4.1*		
Sensors	<i>Filter Time Const.</i>	4.2.1*
4.2*	<i>Hold after Cal.</i>	4.2.2*
Logger	<i>Log Interval</i>	4.3.1*
4.3*	<i>Clear Logger</i>	4.3.2*
	<i>Eject SD Card</i>	4.3.3*



8.5. Installation (Main Menu 5)

Sensors	TOC	Measurement	Operation Mode	<i>Pharma</i>
5.1*	5.1.1*	5.1.1.1*	5.1.1.1.1*	<i>UPW</i>
			Compensation	<i>CO2</i>
			5.1.1.1.2*	<i>Coefficient</i>
		Parameters	<i>Offset</i>	5.1.1.2.1*
		(UPW only)	<i>Factor</i>	5.1.1.2.2*
		5.1.1.2*	<i>Standard</i>	5.1.1.2.3*
	Cond. 1 and 2	<i>Cell Constant</i>	5.1.x.1*	
	5.1.2/3*	<i>Temp. Corr.</i>	5.1.x.2*	
	Flow	<i>Flow measurement</i>	5.1.4.1*	
	5.1.4*			
Signal Outputs	Signal Output 1 and 2	<i>Parameter</i>	5.2.1.1*	
5.2*	5.2.1 and 5.2.2*	<i>Current Loop</i>	5.2.1.2*	
		<i>Function</i>	5.2.1.3*	
		<i>HOLD Mode</i>	5.2.1.4*	
		Scaling	<i>Range Low</i>	5.2.1.50.10*
		5.2.1.50*	<i>Range High</i>	5.2.1.50.20*
Relay Contacts	Alarm Relay	Sensors	TOC	<i>Alarm High</i>
5.3*	5.3.1*	5.3.1.1*	5.3.1.1.1*	<i>Alarm Low</i>
				<i>Hysteresis</i>
				<i>Delay</i>
			Cond. 1 and 2	<i>Alarm High</i>
			5.3.1.1.2/3*	<i>Alarm Low</i>
				<i>Hysteresis</i>
				<i>Delay</i>
		Sample Temp.	Temp. 1 and 2	<i>Alarm High</i>
		5.3.1.2*		<i>Alarm Low</i>
		Sample Flow	<i>Alarm High</i>	5.3.1.3.1*
		5.3.1.3*	<i>Alarm Low</i>	5.3.1.3.2*
		Case Temp.	<i>Alarm High</i>	5.3.1.4.1*
		5.3.1.4*	<i>Alarm Low</i>	5.3.1.4.2*

	Relay 1 and 2	<i>Function</i>	5.3.2.1*	* Menu numbers
	5.3.2 / 5.3.3*	<i>Parameter</i>	5.3.2.2*	
		<i>Setpoint</i>	5.3.2.300*	
		<i>Hysteresis</i>	5.3.2.400*	
		<i>Delay</i>	5.3.2.5*	
	Input	<i>Active</i>	5.3.4.1*	
	5.3.4*	<i>Signal Outputs</i>	5.3.4.2*	
		<i>Output</i>	5.3.4.3*	
		<i>Fault</i>	5.3.4.4*	
		<i>Delay</i>	5.3.4.5*	
Miscellaneous	<i>Language</i>	5.4.1*		
5.4*	<i>Set defaults</i>	5.4.2*		
	<i>Load Firmware</i>	5.4.3*		
	Access	Administrator	<i>Name</i>	
	5.4.4*	5.4.4.1*	<i>Function</i>	
			<i>Password</i>	
		User 1–9	<i>Name</i>	
		5.4.4.x*	<i>Function</i>	
			<i>Password</i>	
	<i>Sample ID</i>	5.4.5*		
	<i>Menu timeout</i>	5.4.6*		
Interface	<i>Protocol</i>	5.5.1*	(only with RS485 interface)	
5.5*	<i>Baud rate</i>	5.5.x*		

9. Program List and Explanations

1 Messages

1.1 Pending Errors

- 1.1.5 Provides the list of active errors with their status (active, acknowledged). When all active errors have been acknowledged, the alarm relay is active again. Cleared errors are moved to the message list.

1.2 Maintenance List

- 1.2.5 Provides the list of necessary maintenance. Cleared maintenance messages are moved to the message list.

1.3 Message List

- 1.3.1 Shows the error history: Error code, date and time of issue and status (active, acknowledged, cleared). 64 errors are memorized. Then the oldest error is cleared to save the newest one (circular buffer).

1.4 Audit Trail

- 1.4.1 Shows the audit trail: event, menu, date and time of issue. 256 events are memorized. Then the oldest event is cleared to save the newest error (circular buffer).

2 Diagnostics

2.1 Identification

Designation: Designation of the instrument.
Version: Version of the instrument firmware.
Bootloader: Version of the bootloader.

- 2.1.3 Peripherals:**
 - 2.1.3.1 *Peri2:* Version of the peristaltic pump firmware.
EVG: Version of the UV reactor firmware.
- 2.1.4 Factory Test:** Test date of the mainboard and frontend.
- 2.1.5 Operating Time:** Years, days, hours, minutes, seconds.

2.2 Sensors

2.2.1 Sensors

Current value: Shows the TOC value in ppb.
Cond. 1 and 2: Shows the uncompensated conductivity of sensors 1 and 2 in nS/cm.
Temp. 1 and 2: Shows the temperature of sensors 1 and 2.

2.2.2 History

- 2.2.2.100 *Verification:* Only available if measuring mode "Pharma" is selected. Shows the values of the last verifications. Only for diagnostic purpose. Max. 64 data records are memorized.
- 2.2.2.101 *Calibration:* Only available if measuring mode "UPW" and compensation model "Coefficient" is selected. Shows the values of the last calibrations. Only for diagnostic purpose. Max. 64 data records are memorized.
- 2.2.2.2 *Suitability Test:* Only available if measuring mode "Pharma" is selected. Shows the values of the last system suitability tests. Only for diagnostic purpose. Max. 64 data records are memorized.
- 2.2.2.3 *Grab Sample:* Shows the values of the last grab sample measurements. Only for diagnostic purpose. Max. 64 data records are memorized.

2.2.3 Miscellaneous

Case Temperature: Shows the temperature inside the transmitter.

2.3 Sample

- 2.3.1 *Sample ID:* Shows the programmed code. the code is defined by the user to identify the sample point in the plant.
Sample flow (raw value): Shows the sample flow in l/h and the raw value in Hz.

2.4 I/O State

2.4.1 Relays

- 2.4.1.1 *Alarm Relay:* Active or inactive
Relays 1 and 2: Active or inactive
Input: Open or closed

2.4.2 Signal Outputs

- 2.4.2.1 *Signal Outputs 1 and 2:* Current in mA
Signal Outputs 3 and 4: Current in mA (if option is installed)



2.5 SD Card

2.5.1 *Status*: Shows the status of the SD card.

2.6 Interface

Settings of the installed communication option (if any).

3 Maintenance

3.1 Verification

Only available if measuring mode “Pharma” is selected. For further details, see [Verification](#), p. 44.

3.1 Calibration

Only available if measuring mode “UPW” and compensation model “Coefficient” is selected. For further details, see [Calibration](#), p. 46.

3.20 Suitability Test

Only available if measuring mode “Pharma” is selected. For further details, see [System Suitability Test \(SST\)](#), p. 47.

3.30 Service

3.30.1 Simulation

To simulate a value or a relay state, select

- ◆ alarm relay
- ◆ relay 1 and 2
- ◆ signal outputs 1 and 2
- ◆ signal outputs 3 and 4 (if option is installed)

Change the value or state of the selected item with the arrow keys. Press [Enter].

⇒ *The value is simulated by the relay/signal output.*

At the absence of any key activities, the instrument will switch back to normal mode after 20 min.

3.30.1.1 Relays

3.30.1.1.1	<i>Alarm relay:</i>	Active or inactive
3.30.1.1.2	<i>Relay 1:</i>	Active or inactive
3.30.1.1.3	<i>Relay 2:</i>	Active or inactive

3.30.1.2 Signal outputs

3.30.1.2.1	<i>Signal outputs 1 and 2:</i>	Current in mA
3.30.1.2.2	<i>Signal outputs 3 and 4:</i>	Current in mA

3.30.2 Lamp

- 3.30.2.1 *Exchange Lamp:* Starts the pump in reverse mode to empty the system. Follow the instructions on the screen.
- 3.30.2.2 *Reset hours counter:* Resets the counter after the lamp has been exchanged.

- 3.30.3 **Fill system:** Starts the peristaltic pump to fill the system e.g. after start-up or maintenance. Follow the instructions on the screen



3.30.4 Test Modules:

3.30.4.1 *Lamp*: Switch lamp on or off.

3.30.4.2 *Peri2*: Switch peristaltic pump on or off.

3.30.4.3 *Solenoid Valve 1*: Switch valve on or off.

3.30.4.4 *Solenoid Valve 2*: Switch valve on or off.

3.30.4.5 *Solenoid Valve 3*: Switch valve on or off.

3.30.4.6 Current values: Shows the current values in ppb if compensation model "CO2" is selected:

- ♦ TOC in ppb

- ♦ TIC in ppb

- ♦ TC in ppb

If compensation model "Coefficient" is selected:

- ♦ TOC in ppb

- ♦ Cond. 1 in nS

- ♦ Cond. 2 in nS

3.30.5 *DeltaT Cal.:* Manual start of the deltaT calibration.

Note: *The flow calibration is started automatically when the temperature in the reactor housing rises or falls by more than 3 °C.*

3.4 Set Time

Adjust date and time.

4 Operation

4.1 Grab Sample

See [Grab Sample](#), p. 41.

4.2 Sensors

- 4.2.1 *Filter Time Constant:* Used to damp noisy signals. The higher the filter time constant, the slower the system reacts to changes of the measured value.
Range: 5–300 s
- 4.2.2 *Hold after Cal.:* Delay permitting the instrument to stabilize again after calibration. During calibration plus hold time, the signal outputs are frozen (held on last valid value), alarm values, limits are not active.
Range: 0–6000 s

4.3 Logger

The instrument is equipped with an internal logger. The logger data can be copied to the SD card.

- 4.3.1 *Log Interval:* Select a convenient log interval.
Range: 1 s, 5 s, 1 min, 5 min, 10 min, 30 min or 1 h.
- 4.3.2 *Clear Logger:* If confirmed with yes, the complete logger data is deleted. A new data series is started.
- 4.3.3 *Eject SD Card:* With this function all logger data are copied to the SD card and the SD card can be removed.

5 Installation

5.1 Sensors

5.1.1 TOC

5.1.1.1 Measurement

5.1.1.1.1 *Operation Mode* (see [Measuring modes, p. 8](#))

Operation Mode
Pharma
UPW

5.1.1.1.2 Compensation (only visible in UPW mode)

5.1.1.1.2.1 *Compensation*

Compensation
CO2
Coefficient

5.1.1.1.2.2 *Coefficient*: Changing the percent value “Coefficient” has an effect on the values displayed as process values in the conductivity model “Coefficient”. These values are converted to a reference temperature of 25 °C and compensated with the preset percent value of the Coefficient (see [Conductivity model coefficient, p. 11](#)).
Range: 0–10%

5.1.1.2 Parameters (only visible in UPW mode)

5.1.1.2.11 *Offset*: The offset is set to -0.40 ppb by default.
Range: -200 ppb to 200 ppb

5.1.1.2.21 *Factor*: The factor is set to 1.00 by default. After a calibration, it may be overwritten. In this menu, the factor can be set back or to any other value within the given range.
Range: 0.10–10.0

5.1.1.2.3 *Standard*: Sets the concentration of the sucrose calibration standard. Only visible if conductivity model is set to Coefficient.
Range: 100 ppb–1.00 ppm

5.1.x Cond. 1 and 2

5.1.x.1 *Cell Constant*: Set cell constant (zk) of conductivity sensors 1 and 2. See labels on the sensors.
Range: 0.0100–0.0800 cm⁻¹

5.1.x.2 *Temp. Corr*: Set temperature correction (dt) of conductivity sensors 1 and 2. See labels on the sensors.
Range: -1.00 to +1.00 °C

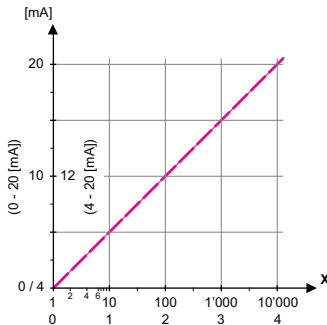

X Measured value (logarithmic)

5.2.1.4 **HOLD mode:** If set to “hold”, the last measured value is displayed during a test.
 If set to “cont”, the actual test value is displayed during a test.
 Available values: hold, cont.

5.2.1.40 Scaling: Enter beginning and end point (range low and high) of the linear or logarithmic scale. In addition, the midpoint for the bilinear scale.

Parameter TOC:

5.2.1.40.1x Range low: 0.00 ppb to 2.0 ppm

5.2.1.40.2x Range high: 50 ppb to 2.0 ppm

Parameters Cond. 1 and Cond. 2:

5.2.1.40.1x Range low: 0.00 nS to 20.0 μS

5.2.1.40.2x Range high: 0.00 nS to 20.0 μS

Parameters Temp. 1 and Temp. 2:

5.2.1.40.16 Range low: -30 °C to 130 °C

5.2.1.40.26 Range high: -30 °C to 130 °C

Parameters Conc. 1 and Conc. 2:

5.2.1.40.17 Range low: 0.00 ppb to 2.0 ppm

5.2.1.40.27 Range high: 50 ppb to 2.0 ppm

5.3 Relay Contacts

5.3.1 Alarm Relay: The alarm relay is used as cumulative error indicator. Under normal operating conditions the contact is active.

The contact is inactive at:

- ◆ Power loss
- ◆ Detection of system faults like defective sensors or electronic parts
- ◆ High case temperature
- ◆ Process values out of programmed ranges.

Program alarm levels, hysteresis values and delay times for the following parameters:

- ◆ TOC
- ◆ Conductivity 1
- ◆ Conductivity 2
- ◆ Sample Temp. 1
- ◆ Sample Temp. 2
- ◆ Sample flow
- ◆ Case Temperature

5.3.1.1 Sensors

5.3.1.1.1 TOC

5.3.1.1.1.1 *Alarm high:* If the measured value rises above the alarm high value, the alarm relay becomes inactive and E001 is displayed in the message list.

Range: 0.00 ppb–2.00 ppm

5.3.1.1.1.25 *Alarm low:* If the measured value falls below the alarm low value, the alarm relay becomes inactive and E002 is displayed in the message list.

Range: 0.00 ppb–2.00 ppm

5.3.1.1.1.35 *Hysteresis:* Within the hysteresis range, the alarm relay does not switch. This prevents damage of relay contacts when the measured value fluctuates around the alarm value.

Range: 0.000 ppb–2.00 ppm

5.3.1.1.1.45 *Delay:* Waiting time before the alarm relay becomes inactive after the measured value has risen above or fallen below the programmed alarm value.

Range: 0–28'800 s

5.3.1.1.2 Cond. 1

5.3.1.1.2.1 *Alarm high:* If the measured value rises above the alarm high value, the alarm relay becomes inactive and E003 is displayed in the message list.

Range: 0.0 nS–5.00 µS



- 5.3.1.1.2.25 *Alarm low:* If the measured value falls below the alarm low value, the alarm relay becomes inactive and E004 is displayed in the message list.
Range: 0.0 nS–5.00 μ S
- 5.3.1.1.2.35 *Hysteresis:* Within the hysteresis range, the alarm relay does not switch. This prevents damage of relay contacts when the measured value fluctuates around the alarm value.
Range: 0.0 nS–5.00 μ S
- 5.3.1.1.2.45 *Delay:* Waiting time before the alarm relay becomes inactive after the measured value has risen above or fallen below the programmed alarm value.
Range: 0–28'800 s
- 5.3.1.1.3 Cond 2**
- 5.3.1.1.3.1 *Alarm high:* If the measured value rises above the alarm high value, the alarm relay becomes inactive and E005 is displayed in the message list.
Range: 0.0 nS–7.00 μ S
- 5.3.1.1.3.25 *Alarm low:* If the measured value falls below the alarm low value, the alarm relay becomes inactive and E006 is displayed in the message list.
Range: 0.0 nS–7.00 μ S
- 5.3.1.1.3.35 *Hysteresis:* Within the hysteresis range, the alarm relay does not switch. This prevents damage of relay contacts when the measured value fluctuates around the alarm value.
Range: 0.0 nS–7.00 μ S
- 5.3.1.1.3.45 *Delay:* Waiting time before the alarm relay becomes inactive after the measured value has risen above or fallen below the programmed alarm value.
Range: 0–28'800 s
- 5.3.1.2 Sample Temp**
- 5.3.1.2.1 Sample Temp. 1**
- 5.3.1.2.1.1 *Alarm high:* If the sample temperature rises above the programmed value E007 is issued.
Range: 30–50 °C
- 5.3.1.2.1.2 *Alarm low:* If the sample temperature falls below the programmed value E008 is issued.
Range: 5–45 °C
- 5.3.1.2.2 Sample Temp. 2**
- 5.3.1.2.2.1 *Alarm high:* If the sample temperature rises above the programmed value E021 is issued.
Range: 30–50 °C
- 5.3.1.2.2.2 *Alarm low:* If the sample temperature falls below the programmed value E022 is issued.
Range: 5–45 °C

5.3.1.3 Sample Flow

- 5.3.1.3.1 *Alarm high:* If the sample flow rises above the programmed value, E009 is issued.
Range: 5.0–8.0 l/h
- 5.3.1.3.24 *Alarm low:* If the sample flow falls below the programmed value, E010 is issued.
Range: 2.5–5.0 l/h

5.3.1.4 Case Temp.:

- 5.3.1.4.1 *Case Temp. high:* Set the alarm high value for the temperature of the transmitter housing. If the value rises above the programmed value E013 is issued.
Range: 30–75 °C
- 5.3.1.4.2 *Case Temp. low:* Set the alarm low value for the temperature of the transmitter housing. If the value falls below the programmed value E014 is issued.
Range: -10 to +20 °C

5.3.x Relay 1 and 2: The function of relay contacts 1 or 2 can be defined by the user.

Note: The navigation in the menu Relay 1 and Relay 2 is identical. For reason of simplicity only the menu numbers of Relay 1 are used in the following.

- 1 First select the function:
 - Limit upper/lower,
 - Fieldbus
 - Hold
- 2 Then enter the necessary data depending on the selected function.

5.3.2.1 Function = Limit upper/lower

When the relays are used as upper or lower limit switches, program the following:

- 5.3.2.2 *Parameter:* Select a process value (TOC, conductivity, temperature, concentration).
- 5.3.2.300 *Setpoint:* If the measured value rises above respectively falls below the setpoint, the relay is activated.

Parameter	Range	
TOC	0.00 ppb–2.00 ppm	
Cond. 1 and 2	0.0 nS–3.00 mS	
Temp. 1 and 2	-30 °C to +130 °C	
Conc. 1 and 2	0.00 ppb–2.00 ppm	conductivity model “CO ₂ ” only.



5.3.2.400 *Hysteresis*: within the hysteresis range, the relay does not switch. This prevents damage of relay contacts when the measured value fluctuates around the alarm value.

Parameter	Range	
TOC	0.00 ppb–2.00 ppm	
Cond. 1 and 2	0.0 nS–3.00 mS	
Temp. 1 and 2	0 °C to +100 °C	
Conc. 1 and 2	0.00 ppb–2.00 ppm	conductivity model “CO ₂ ” only.

5.3.2.5 *Delay*: Time by which the switching of the relay is delayed after the measured value has risen above or fallen below the programmed setpoint.
 Range. 0–600 s

5.3.2.1 Function = Fieldbus

The relays are switched via Profibus or Modbus.

5.3.2.1 Function = Hold

The relay becomes active when the online measurement is interrupted, e.g., for a test.

5.3.4 Input: The functions of the relays and signal outputs can be defined depending on the position of the input contact, i.e. no function, closed or open.

5.3.4.1 *Active*: Define when the input should be active:

No: Input is never active.

When closed: Input is active when the input relay is closed

When open: Input is active when the input relay is open

5.3.4.2 *Signal Outputs*: Select the operation mode of the signal outputs when the input is active:

Continuous: Signal outputs continue to issue the measured value.

Hold: Signal outputs hold the last valid measured value. Errors, except fatal errors, are not issued.

Off: Sets the signal outputs to 0 or 4 mA. Errors, except fatal errors, are not issued.

5.3.4.3 *Output/Control*: (relay or signal output):

Continuous: Controller continues normally.

Hold: Controller continues based on the last valid value.

Off: Controller is switched off.

- 5.3.4.4 *Fault:*
- No:* No message is issued in pending error list and the alarm relay does not become inactive when the input is active. Message E024 is stored in the message list.
- Yes:* Message E024 is issued and stored in the message list and the alarm relay becomes inactive when the input is active.
- 5.3.4.5 *Delay:* Time that the instrument waits after the input is deactivated, before returning to normal operation.
Range: 0–6'000 s

5.4 Miscellaneous

- 5.4.1 *Language:* Set the desired language.
Available settings: German, English, French, Spanish.
- 5.4.2 *Set defaults:* The instrument can be reset to factory default values in three different ways:
- ◆ **Calibration:** Sets calibration values back to default. All other values are kept in memory.
 - ◆ **In parts:** Communication parameters are kept in memory. All other values are set back to default values.
 - ◆ **Completely:** Sets back all values including communication parameters.
- 5.4.3 *Load Firmware:* Firmware updates should be done by instructed service personnel only.
- 5.4.4 **Access:** To activate password protection, perform the following steps:
- 1 Activate the required number of users 1 to 9 by setting a password different from "00000000".
 - 2 Enter a meaningful name for each user.
 - 3 Set the function of each user to Administrator, Service or Operator.
 - 4 Set a password different from "00000000" for the predefined administrator user in menu 5.4.4.1.
⇒ *After this, the Messages, Diagnosis, Maintenance, Operation and Installation menus can no longer be accessed without entering a password.*
- 5.4.4.4.1 **Administrator**
Pre-defined administrator user.
- 5.4.4.1.1 *Name:* not changeable.
- 5.4.4.1.2 *Function:* not changeable.



5.4.4.1.3 *Password:* Set a password with eight characters, containing at least one upper case letter, one lower case letter and one number.

5.4.4.2 User 1

5.4.4.2.1 *Name:* Enter the name of the user.

5.4.4.2.2 *Function:*

- ◆ Administrator: Access to all menus. Only an administrator can assign user rights and passwords to users 1 to 9.
- ◆ Service: Access to all menus except Installation.
- ◆ Operator: Access to the Messages and Diagnostic menus.

5.4.4.2.3 *Password:* Set a password containing at least one upper case letter, one lower case letter and one number.

5.4.4.3 User 2

See User 1.

5.4.4.4 User 3

See User 1.

5.4.4.5 User 4

See User 1.

5.4.4.6 User 5

See User 1.

5.4.4.7 User 6

See User 1.

5.4.4.8 User 7

See User 1.

5.4.4.9 User 8

See User 1.

5.4.4.10 User 9

See User 1.

5.4.5 *Sample ID:* Enter a meaningful text, e.g. the KKS number.

5.4.6 *Menu Timeout:* Time after which password-protected menus are automatically exited if no button has been pressed and no process is running.

Range: 2–20 min

5.5 Interface

Select one of the following communication protocols.

5.5.1 *Protocol: Profibus*

- 5.5.20 Device address: Range: 0–126
- 5.5.30 ID no.: Range: Analyzer; Manufacturer; Multivariable
- 5.5.40 Local operation: Range: Enabled, Disabled

5.5.1 *Protocol: Modbus RTU*

- 5.5.21 Device address: Range: 0–126
- 5.5.31 Baud rate: Range: 1 200–115 200 Baud
- 5.5.41 Parity: Range: none, even, odd

5.5.1 *Protocol: HART*

- Device address: Range: 0–63



10. Default Values

Operation

Sensors	Filter time constant:	30 s
	Hold after Calibration:	300 s
Logger	Logger Interval:.....	30 min
	Clear Logger:.....	no

Installation

Sensors	TOC: Measurement: Operation Mode:	Pharma
	TOC: Measurement: Compensation:	CO2
	<i>If Compensation = Coefficient:</i>	
	Coefficient:.....	4.50%
	<i>Operation Mode UPW only:</i>	
	TOC: Parameters: Offset:	-0.40 ppb
	TOC: Parameters: Factor:.....	1.00
	TOC: Parameters: Standard:	1.00 ppm
	Cond. 1 and 2: Cell Constant:	0.0360 cm ⁻¹
	Cond. 1 and 2: Temp. corr.:	0.00°C
	Flow: Flow measurement:	Q-Flow
Signal	Parameter:	TOC
Output 1	Current loop:	4–20 mA
	Function:	linear
	HOLD Mode:.....	hold
	Scaling: Range low:	0.00 ppb
	Scaling: Range high:	1.00 ppm
	Parameter: Scaling: Cond. 1 and Cond. 2	
	Scaling: Range low:	0.0 nS
	Scaling: Range high:	10.0 µS
	Parameter: Scaling: Temp. 1 and Temp. 2	
	Scaling: Range low:	0.0 °C
	Scaling: Range high:	50 °C
	Parameter: Scaling: Conc. 1	
	Scaling: Range low:	0.00 ppb
	Scaling: Range high:	100 ppb
	Parameter: Scaling: Conc. 2	
	Scaling: Range low:	0.00 ppb
	Scaling: Range high:	1.00 ppm

Signal	Parameter:	Temperature 1
Output 2	Current loop:	4–20 mA
	Function:	linear
	Scaling: Range low:	0.0 °C
	Scaling: Range high:	50.0 °C
Alarm Relay	Sensors: TOC: Alarm high:	2.00 ppm
	Sensors: TOC: Alarm low:	0.00 ppb
	Sensors: TOC: Hysteresis:	10.0 ppb
	Sensors: TOC: Delay:	30 s
	Sensors: Cond. 1: Alarm high:	3.00 µS
	Sensors: Cond. 1: Alarm low:	0.0 nS
	Sensors: Cond. 1: Hysteresis:	100.0 nS
	Sensors: Cond. 1: Delay:	30 s
	Sensors: Cond. 2: Alarm high:	5.00 µS
	Sensors: Cond. 2: Alarm low:	0.0 nS
	Sensors: Cond. 2: Hysteresis:	100.0 nS
	Sensors: Cond. 2: Delay:	30 s
	Sample Temp.: Temp. 1 and 2: Alarm High:	50 °C
	Sample Temperature: Temp. 1 and 2: Alarm Low:	30 °C
	Sample Flow: Alarm high:	6.0 l/h
	Sample Flow: Alarm low:	3.0 l/h
	Case temperature: Alarm High:	65 °C
	Case temperature: Alarm Low:	0 °C
Relay 1 and 2	Function:	Limit upper
	Parameter: TOC	
	Setpoint:	1.00 ppm
	Hysteresis:	10.0 ppb
	Delay:	30 s
	Parameter: Cond. 1	
	Setpoint:	10.0 µS
	Hysteresis:	1.00 µS
	Delay:	30 s
	Parameter: Cond. 2	
	Setpoint:	10.0 µS
	Hysteresis:	100 nS
	Delay:	30 s
	Parameter: Temp. 1 and 2	
	Setpoint:	50 °C
	Hysteresis:	1.0 °C
	Delay:	30 s
	Parameter: Conc. 1	
	Setpoint:	100 ppb
	Hysteresis:	10.0 ppb
	Delay:	30 s

	Parameter: Conc. 2	
	Setpoint:	1.00 ppm
	Hysteresis:	10.0 ppb
	Delay:	30 s
Input	Active:	when closed
	Signal Outputs:	hold
	Output:	off
	Fault:	yes
	Delay:	10 s
Miscellaneous	Language:	English
	Set default:	no
	Load firmware:	no
	Access: Password: Administrator:	00000000
	Access: Password: User 1 ... 9 :	00000000
	Menu timeout:	10 min

Swan Products - Analytical Instruments for:



Swan is represented worldwide by subsidiary companies and distributors and cooperates with independent representatives all over the world. For contact information, please scan the QR code.

Swan Analytical Instruments · CH-8340 Hinwil
www.swan.ch · swan@swan.ch

 **MADE IN
SWITZERLAND**

